

NAU Solar Control 3020

Mounting

Connection

Operation

Troubleshooting



Thank you for buying this product
Please read this manual carefully to get the best performance from this unit.

Solar Control 3020

EN
Manual

www.nau-gmbh.de

Safety advice

Please pay attention to the following safety advice in order to avoid danger and damage to people and property.

Appropriate usage

This product is to be used in solar thermal systems and conventional heating systems in compliance with the technical data specified in these instructions (see p.3).

Improper use excludes all liability claims

Instructions

Attention should be paid to

- valid local regulations
 - the statutory provisions for prevention of industrial accidents,
 - the statutory provisions for environmental protection,
 - the Health and Safety at Work Act 1974
 - Part P of the Building Regulations 2005
 - BS7671 Requirements for electrical installations and relevant safety regulations of DIN, EN, DVGW, TRGI, TRF and VDE.
- These instructions are exclusively addressed to authorised skilled personnel.
- Only qualified electricians should carry out electrical works.
 - Initial installation must be effected by qualified personnel named by the manufacturer

Table of contents

Safety advice 2

Technical data and overview of functions 3

1. Installation..... 4

 1.1 Mounting4

 1.2 Electrical connection..... 4

 1.2.1 Overview of electrical connections..... 4

 1.2.2 Actuators5

 1.2.3 Data communication / bus..... 5

 1.2.4 Sensors.....6

 1.2.5 Mains connection6

2. Operation and function 7

 2.1 Adjustment keys.....7

 2.2 Control lamp..... 7

 2.3 Menu structure.....8

 2.4 User codes8

 2.5 Menu overview.....9

3. Commissioning 10

 3.1 Commissioning the controller10

 3.2 Basic systems and hydraulic variants.....10

 3.3 Function blocks12

 3.4 Adjusting the controller step-by-step14

 3.5 Overview of relay and sensor allocations.....15

4. Functions and options 24

 4.1 Menu: Solar.....24

 4.2 Menu: Arrangement30

 4.2.1 Heating circuits.....33

 4.3 Menu: Heat quantity measurement function37

 4.4 Menu: Expert.....38

 4.5 Menu: Manual mode39

5. Troubleshooting 40

6. Accessory 43

Imprint 44

Subject to technical change. Errors excepted.

- 30 schemes to choose from
- speed control, solar operating hours counter and heat quantity measurement
- 13 sensor inputs
- 7 relay outputs
- function control
- VBus®

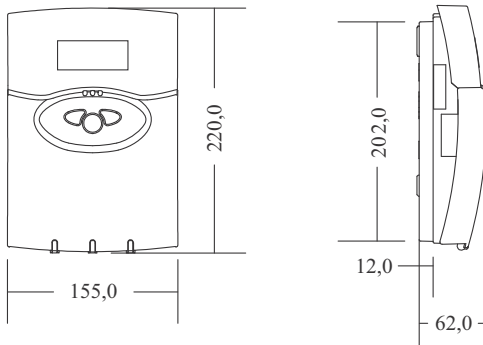

Scope of delivery:

- 1 x Solar Control 3020
- 1 x accessory bag
 - 2 x screw and dowel
 - 8 x strain relief and screw
 - 1 x capacitor 4,7 nF

The Solar Control 3020 controller is designed for solar thermal systems and heating systems. It is preprogrammed for 7 basic systems or 30 schemes which can even be used to control large systems. A multitude of adjustable functions and options are realised by 7 relay outputs, 13 sensor inputs for Pt1000, CS10, V40 and Din. Due to its intelligent and easy-to-understand

system configuration and its integrated calorimeter, the controller also offers the control of complex systems with up to 4 weather-compensated heating circuits. For data communication and remote maintenance, the controller is equipped with the VBus®, which opens the bidirectional way to modules, PCs or data logging.

Technical Data:

Housing: plastic, PC-ABS and PMMA

Protection type: IP 20 / DIN 40 050

Ambient temp.: 0...40°C

Dimensions: 220 x 155 x 62 mm

Mounting: Wall mounting, mounting into patch-panels is possible

Display: 4-line LCD text display

Operation: 3 push buttons at the front

Functions: Solar system controller for use in solar thermal systems and conventional heating systems. With pre-programmed and selectable schemes such as: standard-solar system, 2-store systems, East-/West collector, heating circuit backup, heat exchange control, thermostatic after-heating, solid fuel

boiler, further functions and options such as heat quantity measurement, collector cooling function, tube collector function, frost protection, minimum temperature limitation, speed control, heat yield balancing, function control according to BAW-directives.

Sensor inputs: 10 sensor inputs for Pt1000, 1 x CS10, 1 x V40 and 1 digital input

Relay output: 7 relay outputs: 3 semiconductor relays for speed control, 1 potential-free output (floating relay)

Bus: VBus®

Power supply:

220 ... 240 V~, 50 ... 60 Hz

Switching capacity:

- 1 A (semiconductor relays)
- 2 A (electromechanical relays)
- 4 A (potential-free relay)
- 4 A sum of all relays
- 220 ... 240 V~

Rated impuls voltage: 2,5 kV

Mode of operation:

Type 1.b / Type 1.y

Degree of pollution: 2



Attention: Electrostatic discharge can cause damage of electronic components



Warning: high-voltage components

1. Installation

1.1 Montage

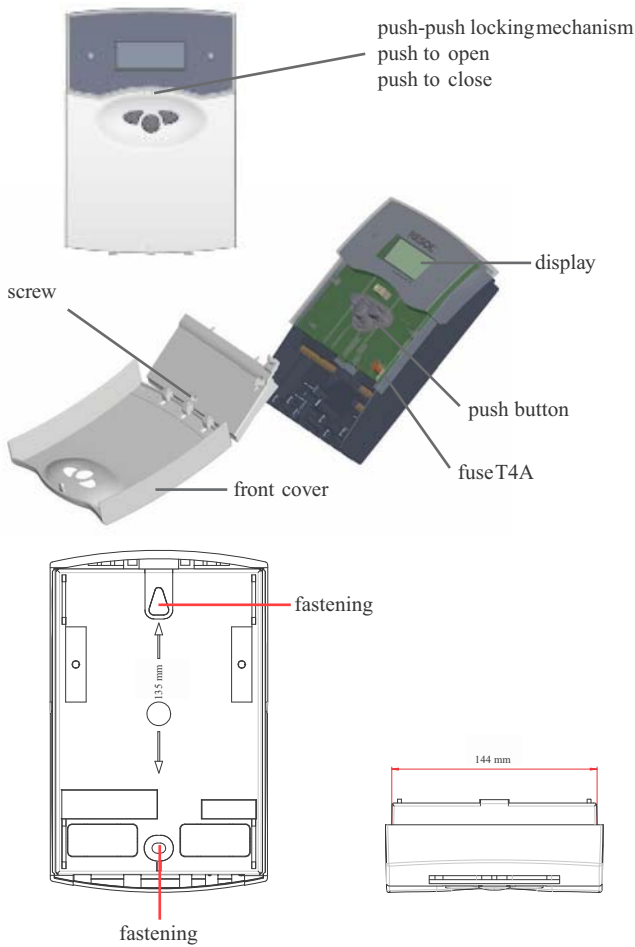

WARNING!

Always disconnect the controller from power supply before opening the housing!

The unit must only be located in dry interior locations. It is not suitable for installation in hazardous locations and should not be placed close to any electromagnetic fields. The controller must additionally be supplied from a double-pole switch with contact gap of at least 3 mm. Please pay attention to separate routing of sensor cables and mains cables.

1. Open the front cover by pushing it. Unscrew the cross-head screw from the cover and remove it along with the front cover from the housing.
2. Mark the upper fastening point on the wall and drill and fasten the enclosed wall plug and screw leaving the head protruding.
3. Hang the housing from the upper fastening point and mark the lower fastening point through the hole in the terminal box (centres 135 mm). Drill and insert the lower wall plug.
4. Hang the housing from the upper fastening point and attach with the lower screw.
5. Carry out connection in accordance with the terminal allocation.
6. Insert cover and attach with the cross-head screw. Close the front cover properly.

1.2 Electrical connection

1.2.1 Overview of electrical connections

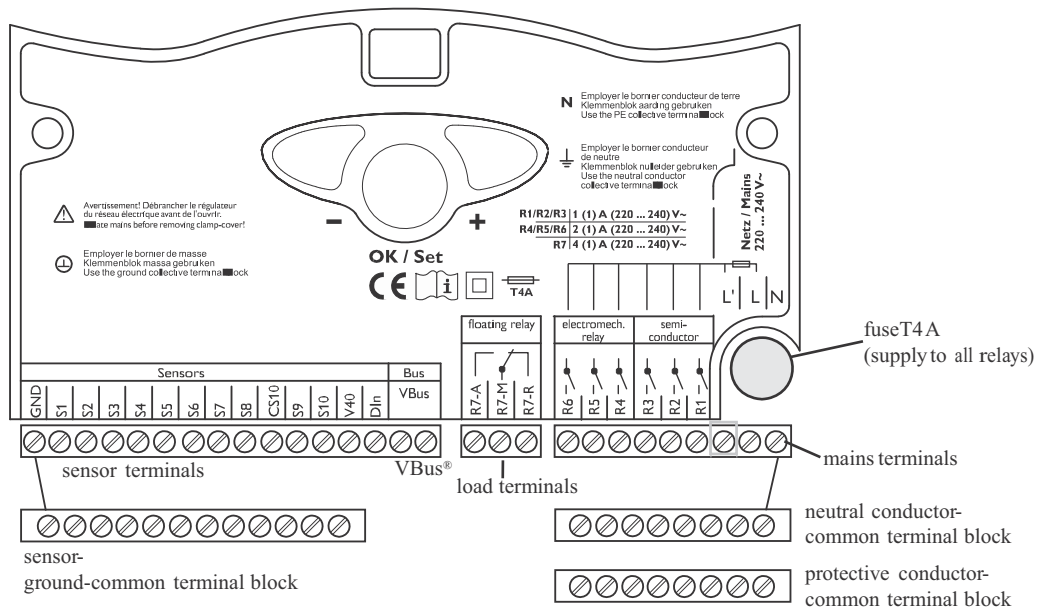

1.2.2 Actuators
(pumps, valves etc.)

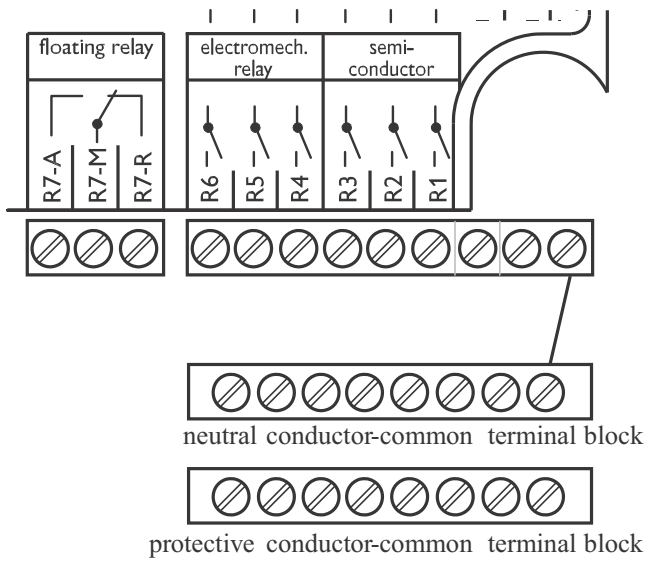

The controller is equipped with 7 relays to which loads (actuators) such as pumps, valves and auxiliary relays can be connected (A= normally open contact; R = normally closed / break contact):

- **Relays R1...R3** are semiconductor relays, designed for pump speed control:
 - R1...R3 = normally open R1...R3
 - N = neutral conductor N (common terminal block)
 - PE = protective conductor PE (common terminal block)
- **Relays R4, R5 and R6** are electromechanical relays with 1 normally open contact:
 - R4,R5,R6 = normally open R4,R5,R6
 - N = neutral conductor N (common terminal block)
 - PE = protective conductor PE (common terminal block)
- **Relay R7** is a potential-free (floating) relay with change-over contact:
 - R7-M = center contact R7
 - R7-A = normally open R7
 - R7-R = normally closed R7

In all systems with after-heating, R7 switches in parallel to R3 (via function block) in order to provide boiler demand if necessary.

Note:

Relays R1 to R3 are semiconductor relays for pump speed control. A minimum load of 20 W (power consumption of the load) is required for faultless function. The capacitor from the accessory bag must be connected in parallel to the respective relay output if it feeds auxiliary relays, motor valves, etc.

The minimum pump speed must be set to 100% when auxiliary relays or valves are connected.

1.2.3 Data communication / bus

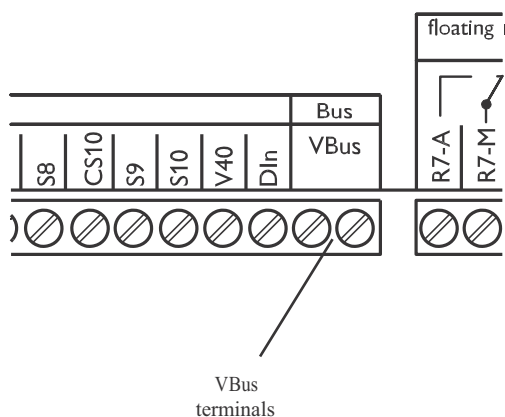

The controller is equipped with the **VBus®** for data transfer with and energy supply to external modules. The connection is carried out at the two terminals marked "VBus" (either polarity). One or more VBus® modules can be connected via this data bus:

- WMZ, calorimeter
- large display/ Smart Display
- Datalogger
- heating circuit modules HKM (up to 3 modules)

1.2.4 Sensors

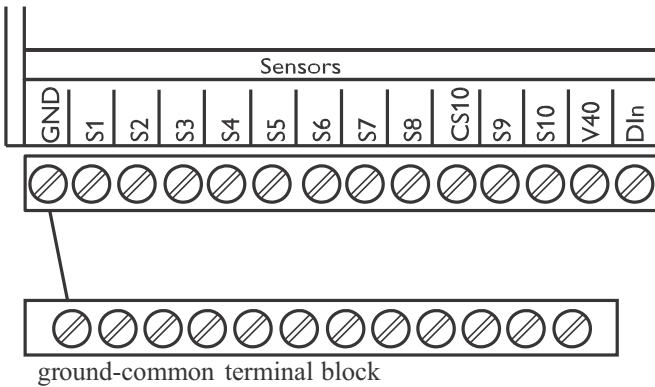

The controller is equipped with 13 sensor inputs in total. The ground connection for the sensors has to be carried out via the ground terminal block (GND).

- **Temperature sensors** have to be connected to the terminals S1 ...S10 and GND (either polarity)
- The **irradiation sensor (CS10)** is to be connected to the terminals CS10 and GND with correct polarity. Connect the terminal GND of the sensor to the terminal GND of the controller (ground terminal block), and the terminal CS of the sensor to the terminal CS10 of the controller.
- A **flowmeter V40** can be connected to the terminals V40 and GND (either polarity).
- An external message signal can be connected to the **digital input Din**. When the signal contact closes the input Din, the message „ !message ext.“ is generated. This signal is treated like an error, which means that the control lamp flashes red and the message relay is possibly energised.

1.2.5 Mains supply

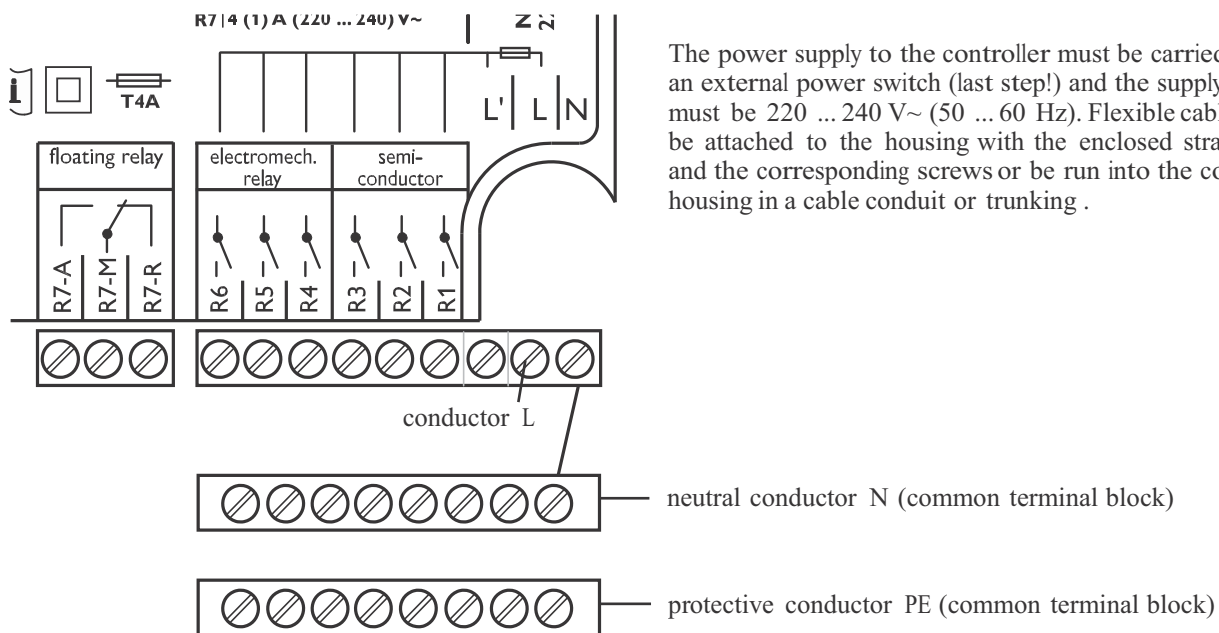

The power supply to the controller must be carried out via an external power switch (last step!) and the supply voltage must be 220 ... 240 V~ (50 ... 60 Hz). Flexible cables must be attached to the housing with the enclosed strain relief and the corresponding screws or be run into the controller housing in a cable conduit or trunking .

2. Operation and function

2.1 Buttons for adjustment

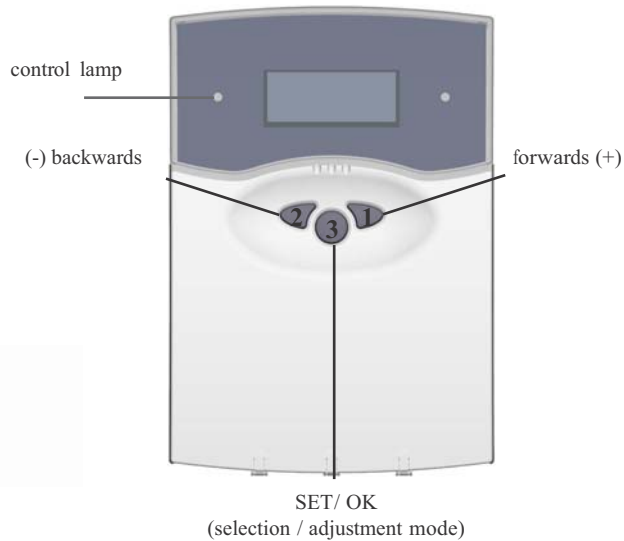

The controller is operated via the 3 push buttons below the display. The forward-button (1) is used for scrolling forward through the menu or to increase the adjustment values. The backward-button (2) is similarly used for scrolling backwards and reducing values. Button 3 is used for selection of the menu lines and for confirmation.

- Briefly press button 3 in order to access the main menu
- Select the requested menu using buttons 1 and 2. Briefly press button 3, the selected submenu is then shown on the display. By selecting the menu line "back", the display returns to the former menu level.
- Press buttons 1, 2 and 3 to scroll until the chosen menu line is reached.
- Briefly press button 3 in the respective menu line to modify adjustment values - „change value“ appears on the display - adjust the requested value by pressing the buttons 1 and 2 (for large intervals, keep the button pressed).
- Briefly press button 3 in order to finish the adjustment.
- To save the change, answer the security inquiry „Save?“ by choosing „yes“ or „no“ (buttons 1 and 2) and confirm with button 3.

• **Note:**

If in the display mode no button is pressed within 4 minutes, the display changes back to measured values menu (in the case of a message, the message menu is indicated).

When button 3 is pressed for 2 seconds, the display changes back to the main menu.

2.2 Control lamp

The controller is equipped with a red-/green control lamp. The following control and system status are signalled as shown:

- green automatic operation
- red flashing: malfunction of the system
- green flashing manual mode

2.3 Menu structure

	main menu
1.	meas. values
2.	reports
3.	Solar
4.	Arrangement
5.	WMZ
6.	manual operation
7.	user code
8.	Expert

The clear-text display shows a 4-line part of the selected menu.

Adjustment and control of the controller are carried out via the menu. When the controller is commissioned, the display level is in the main menu. In the first line of each submenu you will find the option “back”, by means of which it is possible to get to the former menu level. In the following diagrams you will find the complete menu contents; since some of the menu points depend on the system, option or message, in some cases not all of the shown text lines are indicated.

Main menu is shown on the display in the initial state. A selection can be made between 8 submenus.

Note:

The choice of adjustment values and options depends on different functions and the user code. Some only appear in the display if they are available for the adjusted system parameters.

2.4 User codes

- | | |
|-------------|--|
| 1. Expert | Code 0262 (factory setting)
All menus and adjustment values are shown and all adjustments can be altered. |
| 2. User | Code 0077
The expert level is shown, parameter access is restricted. |
| 3. Customer | Code 0000
The expert level is not shown, adjustment values (solar) can be changed partly; modification of options, parameter and balance values is not possible.
For safety reasons, the user code should generally be set to “0000” before the controller is handed to the customer! |

Note:

After the menu point “user code” has been chosen, enter the user code!

2.5 Menu overview

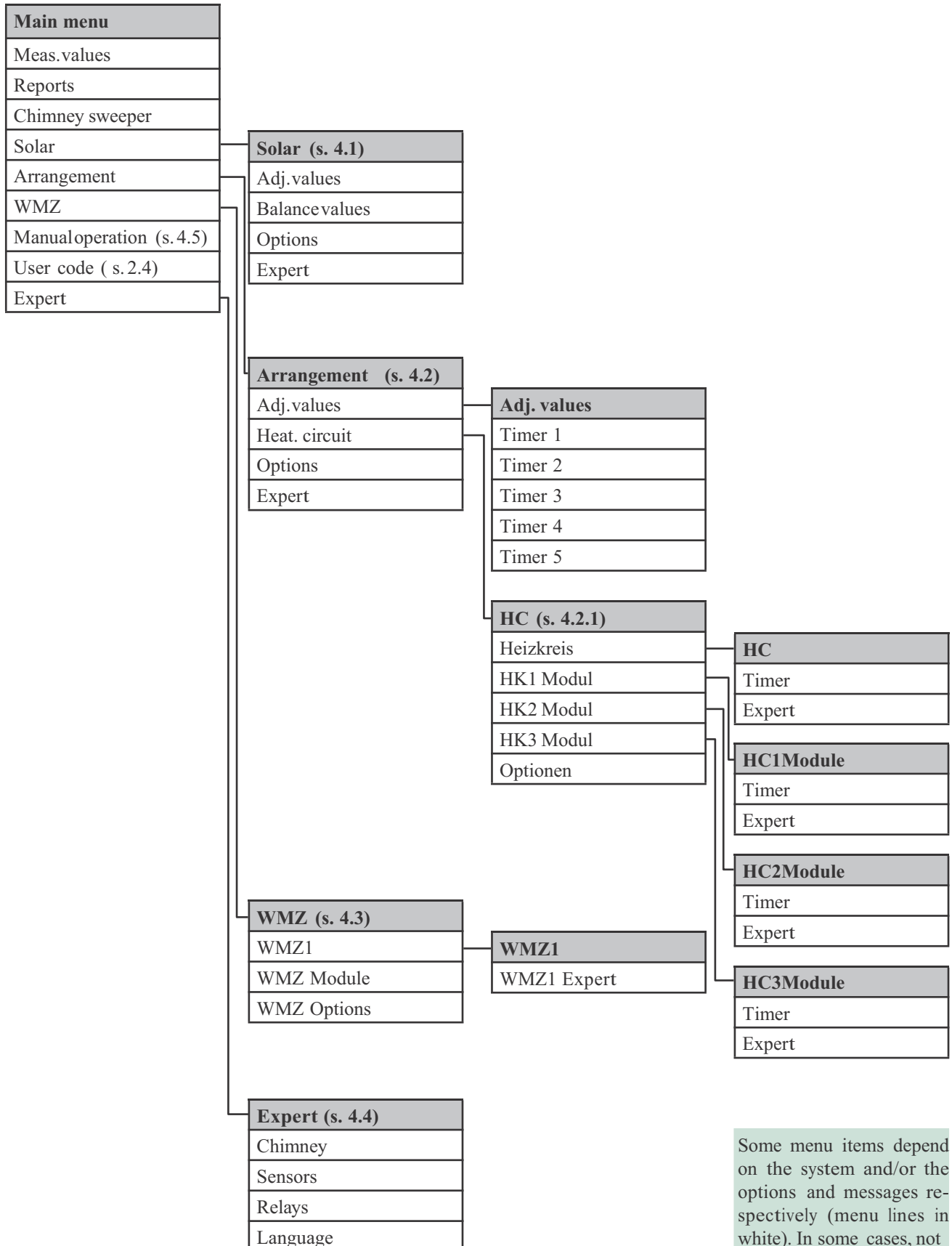

Some menu items depend on the system and/or the options and messages respectively (menu lines in white). In some cases, not all of the lines shown or additional menu lines are indicated.

3. Commissioning

3.1 Commissioning the controller

The controller is partially freely programmable. For special applications, the relays and the corresponding sensors are assigned in steps.

7 basic systems with different hydraulic variants each are pre-programmed.

1. Adjust the basic system; sensors and relays will be allocated automatically (see 3.2 and 4.1).
2. Activate the internal heating circuit module if needed (see 4.2.1). If the corresponding relays are intended for other purposes, connect the external heating module(s) HKM.
3. Activate further options (bypass, external heat exchanger etc. see 4.1 and 4.2.)
4. Select free function blocks for further applications (return preheating, use of further heat sources; see 3.3 and 4.2.)
5. After every step, carry out special adjustments (switching conditions and limits; see 4.1 and 4.2).
6. A heat quantity measurement function (see 4.3) and other functions such as reports or chimney sweeper can be activated.

Alternatively, one of the 30 pre-programmed schemes can be selected (see 4.1).

The controller can be adjusted in steps (see 3.4.). All functions, options and menu items are described in detail in chapter 4.

3.2 Basic systems and hydraulic variants

The controller is preprogrammed for 7 basic systems. The selection depends on the number of heat sources (collector fields) and heat sinks (stores, pool). Factory setting is system 1.

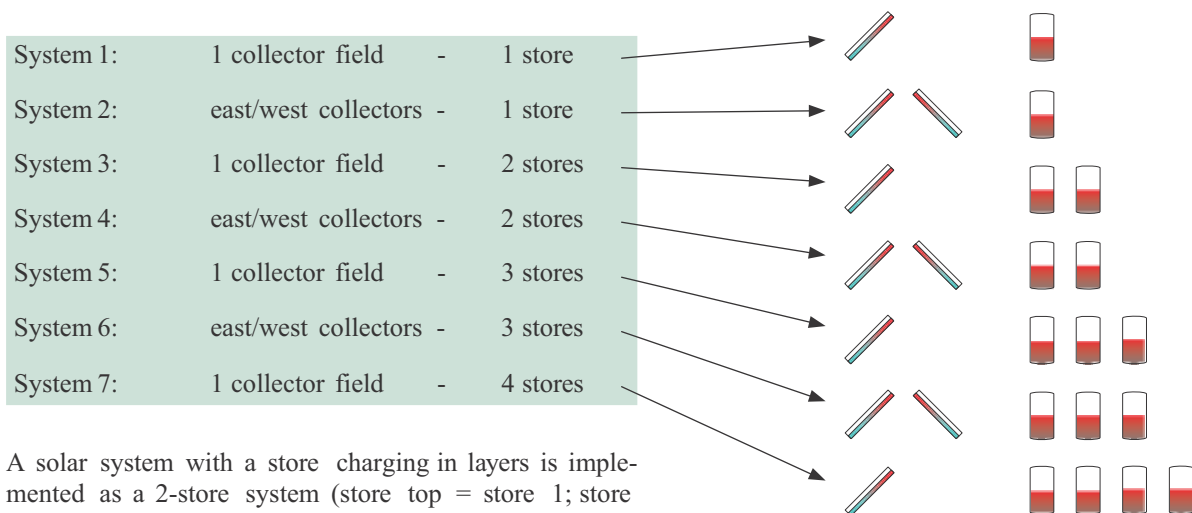

Beginning with system 2, different hydraulic variants are possible (pump or valve control):

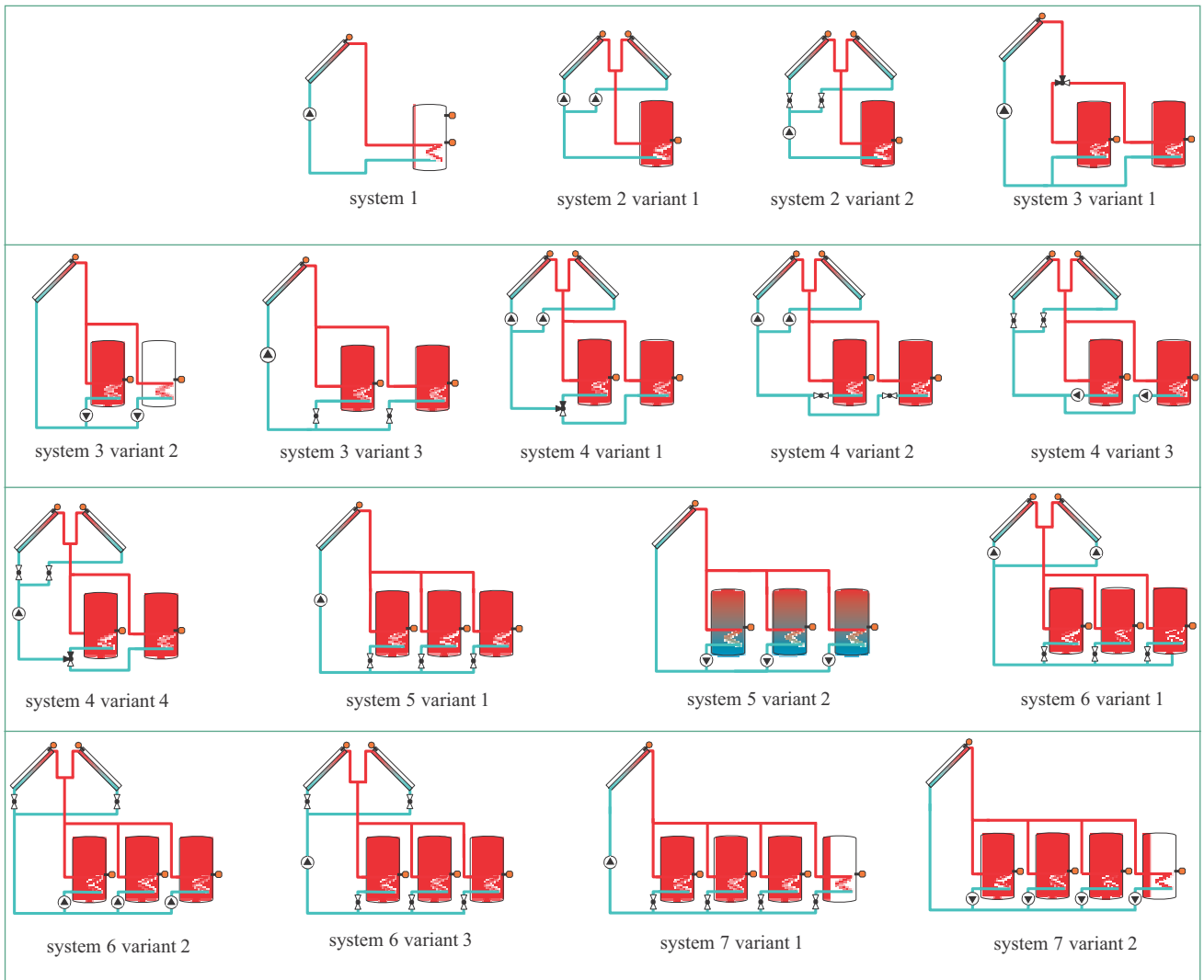

For each variant, the controller allocates the corresponding relays and sensors. The allocations of the most important combinations are shown in 3.5. The system and the variant have to be selected first (Solar/Options/...)!



Important note:

If you select a new system, any previous adjustments which have been done will be set back to the factory settings (reset)!

3.3 Function blocks

Depending on the selected system/variant and other options e.g. internal heating circuit module, certain relays are already assigned. Relays which are not assigned can be allocated to one of the 5 function blocks other uses e.g.(extra valves, stores, heat sources etc).

Each function block provides 4 functions:

- 1 temperature differential function
- 2 thermostat functions
- 1 timer (with 21 time frames)

Function	Function block 1	Function block 2	Function block 3	Function block 4	Function block 5
Thermostat	Thermostat 1- S3	Thermostat 3- S5	Thermostat 5- S5	Thermostat 7- S7	Thermostat 9- S9
	Thermostat 2- S4	Thermostat 4- S6	Thermostat 6- S6	Thermostat 8- S8	Thermostat 10- S10
Differential function DT	DT-5	DT-6	DT-7	DT-8	DT-9
	Sen.1 – S3 Sen.2 – S4	Sen.1 – S5 Sen.2 – S6	Sen.1 – S5 Sen.2 – S6	Sen.1 – S7 Sen.2 – S8	Sen.1 – S9 Sen.2 – S10
Timer	1	2	3	4	5
Relay	3	4	5	6	7

Within a function block, these functions can be activated and combined as required in the menu (Arrangement/Options/...). All switch-on conditions of all activated functions have to be fulfilled in order to energise the relay allocated to the func-

tion block (Arrangement/Adj. values/...). These functions can be compared to switches connected in series:

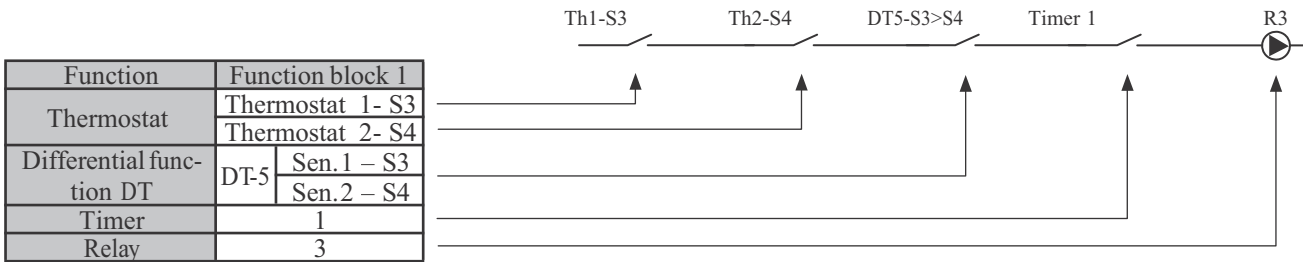

Examples:

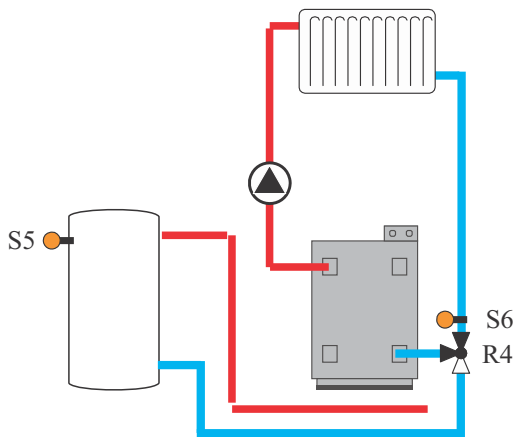

The temperature differential function of a function block has to be activated in order to implement a simple return preheating function.

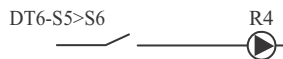

Arrangement/Options/DT-Func6 change setting to „Yes“.

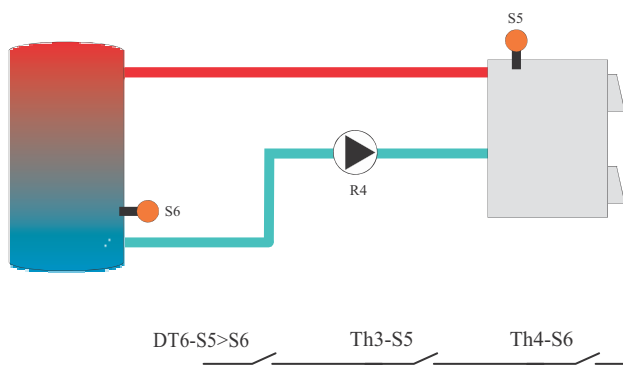

For the use of a further heat source (e.g. solid fuel boiler), one or two thermostat functions can be activated additionally to the differential function, in order to allocate a minimum temperature to the boiler or to limit the maximum store temperature.

arrangement/Options/DT-Func6..... change setting to “Yes“
 arrangement/Options/Thermo.3..... change setting to “Yes“
 arrangement/adj. values/Th3 on..... change value to “60“
 arrangement/adj. values/Th3 off change value to “55“
 arrangement/Options/Thermo.4..... change setting to “Yes“
 arrangement/adj. values/Th4 on change value to “58“
 arrangement/adj. values/Th4 off..... change value to “60“

minimum temperature limitation for the boiler

maximum temperature limitation for the store

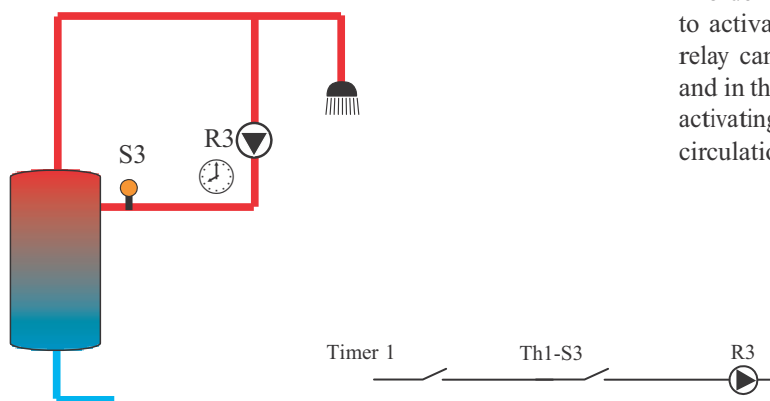

In order to control a circulation pump, it might be enough to activate the timer. With the aid of the 21 time frames, the relay can be switched individually in the morning, at noon and in the evening. This process can be further optimised by activating a thermostat function so that - with a sensor in the circulation line- control is also temperature-dependent.

arrangement/Options/timer 1 change setting to “Yes“
 arrangement/adj. values/timer 1/t1-on..... change value to “06:00“
 arrangement/adj. values/timer 1/t1-off..... change value to “08:00“
 arrangement/adj. values/timer 1/t2-on..... change value to “11:30“
 arrangement/adj. values/timer 1/t2-off change value to “13:30“
 arrangement/adj. values/timer 1/t3-on change value to “18:00“
 arrangement/adj. values/timer 1/t3-off change value to “21:00“
 arrangement/Options/Thermo. 1 change setting to “Yes“
 arrangement/adj. values/Th1 on change value to “50“
 Arrangement/adj. values/Th1 off change value to “55“

3.4 Adjusting the controller step-by-step

Before adjusting the controller, select the language (Expert/language/...).

Points 1.– 3. have to be adjusted for all systems, points 4.– 18. are optional to suit the system requirements, points 19. and 20. should be adjusted before the system is handed over to the operator.

1. Select basic solar system
(Solar/Options/System)
2. Select hydraulic variant (beginning with system 2)
(Solar/Options/loading)
Alternatively to steps 1 and 2:
load system scheme
(solar/options/schematic)
3. Adjust date and time
(arrangement/adj. values/time)
4. Activate internal heating circuit module if needed
(arrangement/heat circuit/Options/hc)
5. Adjust parameters for internal heating circuit module
(Arrangement/heat circuit/hc/...)
6. Activate external heating circuit module(s) if needed
(arrangement/heat circuit/Option/Hc1 (2,3) module)
7. Adjust parameters for external heating circuit module(s)
(arrangement/heat circuits/Hc1 (2,3) Module/...)
8. Activate desired functions with relay allocation (if needed)
 - Bypass
(Solar/Options/Bypass)
 - External heat exchanger
(Solar/Options/Ext. heat ex)
 - Cooling function
(Solar/Options/cool. func.)
 - Parallel relay
(Solar/Options/Par.Relay)
 - After-heating suppression
(Solar/Options /ah suppress.)
 - HSE
(arrangement/Options/hse)
 - Store loading
(arrangement/Options /store load.)
 - Error message
(Expert/message rel.)
9. Activate further functions without relay allocation (if needed):
 - Tube collector function
(Solar/Options/tube col.)
 - Collector cooling function
(Solar/Options/col. cooling)
 - Recooling function
(Solar/Options/Recooling)
 - Frost protection
(Solar/Options/frost prot.)
 - Target temperature
(Solar/Options/target tem.)
 - CS-Bypass
(Solar/Options/CS-Bypass)
10. Adjust special parameters of the selected options
(Solar/adj. values/...),
(Solar/Expert/...) and
(Arrangement/adj. values/...)
11. Activate functions of function blocks (if needed)
(arrangement/Options/...)
12. Adjust switching conditions for the activated functions
(Arrangement/adj. values/...)
13. Activate heat measurement function (if needed)
(WMZ/Options/...)
14. Adjust special parameters
(WMZ/WMZ 1/Expert/...)
15. Deactivate warning message (if needed)
(Expert/...)
16. Carry out sensor offset (if needed)
(Expert/Sensors/...)
17. Increase minimum speed (if needed)
(Expert/Relay/...)
18. Setup and adjust chimney sweeper function (if needed)
(Expert/chimney/...)
19. Carry out relay test
(manual operation/...)
20. Save adjustments
(user code/0000)

3.5 Overview of relay and sensor allocation

System 1

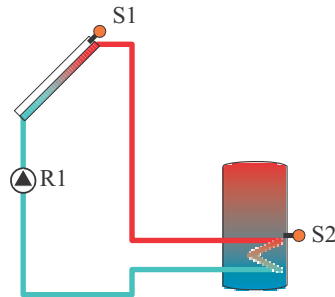

sensor allocation

sen.1	sen.2	sen.3	sen.4	sen.5	sen.6	sen.7	sen.8	sen.9	sen.10	V40	Din
Tcol	Tstb HSE	Th 1 Tby T-HE T1-DT5	Th 2 T2-DT5 T1-AH-HC	Th 3 Th 5 T1-DT6 T1-DT7 T2-AH-HC	Th 4 Th 6 T2-DT6 T2-DT7 HC T-FL	Th 7 T1-DT8 HC T-outd.	Th 8 T2-DT8 HC RTA11	Th 9 T1-DT9 T1 WMZ	Th 10 T2-DT9 T2 WMZ	WMZ	Digitalinput

relay allocation

relay 1	relay 2	relay 3	relay 4	relay 5	relay 6	relay 7
solar pump	ext. HE	func.bl. 1	cooling func. HC-pump func.bl. 2	func.bl.3 HSE bypass par. relay HC-Mi open	func.bl.4 store load. HC-Mi closed	func.bl.5 message rel. AH suppress. HC-afterheat.

System 2 variant 1

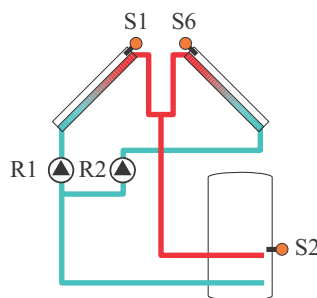

sensor allocation

sen.1	sen.2	sen.3	sen.4	sen.5	sen.6	sen.7	sen.8	sen.9	sen.10	V40	Din
Tcol	Tstb HSE	Th 1 Tby T-HE T1-DT5	Th 2 T2-DT5 T1-AH-HC	Th 3 Th 5 T1-DT6 T1-DT7 T2-AH-HC	Tcol2 Th 4 Th 6 T2-DT6 T2-DT7 HC T-FL	Th 7 T1-DT8 HC T-outd.	Th 8 T2-DT8 HC RTA11	Th 9 T1-DT9 T1 WMZ	Th 10 T2-DT9 T2 WMZ	WMZ	Digitalinput

relay allocation

relay 1	relay 2	relay 3	relay 4	relay 5	relay 6	relay 7
pump col. 1	pump col. 2	func.bl. 1 ext.HE	cooling func. HC-pump func.bl. 2	func.bl.3 HSE bypass par. relay HC-Mi open	func.bl.4 store load. HC-Mi closed	func.bl.5 message rel. AH suppress. HC-afterheat.

System 2 variant 2

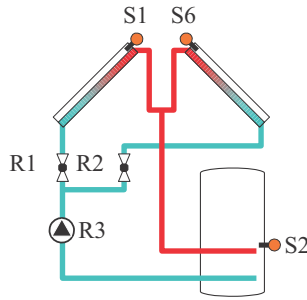

sensor allocation

sen.1	sen.2	sen.3	sen.4	sen.5	sen.6	sen.7	sen.8	sen.9	sen.10	V40	Din
Tcol	Tstb HSE	Tby	T1-AH-HC	Th 3 Th 5 T1-DT6 T1-DT7 T2-AH-HC	Tcol2 Th 4 Th 6 T2-DT6 T2-DT7 HC TFL	Th 7 T1-DT8 HC T-outd.	Th 8 T2-DT8 HC RTA11	Th 9 T1-WMZ	Th 10 T2-DT9 T2-WMZ	WMZ	Digitalinput

relay allocation

relay 1	relay 2	relay 3	relay 4	relay 5	relay 6	relay 7
2-PVcol. 1	2-PVcol.2	solar pump	cooling func. HC-pump func.bl.2	func.bl.3 HSE bypass par. relay HC-Mi open	func.bl.4 store load. HC-Mi closed	func.bl.5 message rel. AH suppress. HC-afterheat.

System 3 variant 1

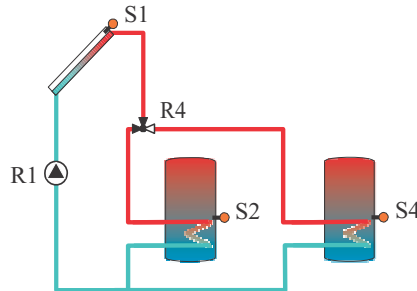

sensor allocation

sen.1	sen.2	sen.3	sen.4	sen.5	sen.6	sen.7	sen.8	sen.9	sen.10	V40	Din
Tcol	Tstb HSE	Th 1 Tby T-HE T1-DT5	Th 2 Tst2b T2-DT5	Th 5 T1-DT7	Th 6 T2-DT7	Th 7 T1-DT8	Th 8 T2-DT8	Th 9 T1-WMZ	Th 10 T2-DT9 T2-WMZ	WMZ	Digitalinput

relay allocation

relay 1	relay 2	relay 3	relay 4	relay 5	relay 6	relay 7
solar pump	ext. HE	func.bl.1	3 PV store 1-2	func.bl.3 HSE bypass par. relay	func.bl.4 store load.	func.bl.5 message rel. AH suppress.

System 3 variant 2

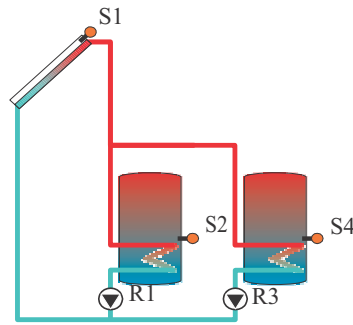

sensor allocation

sen.1	sen.2	sen.3	sen.4	sen.5	sen.6	sen.7	sen.8	sen.9	sen.10	V40	Din
Tcol	Tstb HSE	Tby T-HE	Tst2b	Th 3 Th 5 T1-DT6 T1-DT7	Th 4 Th 6 T2-DT6 T2-DT7	Th 7 T1-DT8	Th 8 T2-DT8	Th 9 T1-DT9 T1 WMZ	Th 10 T2-DT9 T2 WMZ	WMZ	Digitalinput

relay allocation

relay 1	relay 2	relay 3	relay 4	relay 5	relay 6	relay 7
solar pump st1	ext. HE	solar pump st2	func.bl.2	func.bl.3 HSE bypass par. relay	func.bl.4 store load.	func.bl.5 message rel. AH suppress.

System 3 variant 3

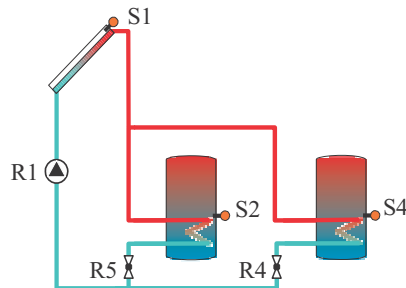

sensor allocation

sen.1	sen.2	sen.3	sen.4	sen.5	sen.6	sen.7	sen.8	sen.9	sen.10	V40	Din
Tcol	Tstb HSE	Th 3 T1-DT5 T-HE	Th 4 T2-DT5 Tst2b	---	---	Th 7 T1-DT8	Th 8 T2-DT8	Th 9 T1-DT9 T1 WMZ	Th 10 T2-DT9 T2 WMZ	WMZ	Digitalinput

relay allocation

relay 1	relay 2	relay 3	relay 4	relay 5	relay 6	relay 7
solar pump	ext. HE	func.bl.1	2 PV store 2	2 PV store 1	func.bl.4 store load.	func.bl.5 message rel. AH suppress.

System 4 variant 1

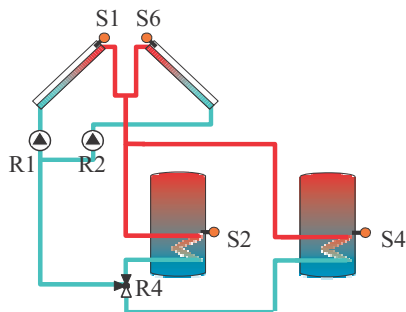

sensor allocation

sen.1	sen.2	sen.3	sen.4	sen.5	sen.6	sen.7	sen.8	sen.9	sen.10	V40	Din
Tcol	Tstb HSE	Th 1 Tby T-HE T1-DT5	Th 2 Tst2b T2-DT5	Th 5 T1-DT7	Tcol2 Th 6 T2-DT7	Th 7 T1-DT8	Th 8 T2-DT8	Th 9 T1-DT9 T1 WMZ	Th 10 T2-DT9 T2 WMZ	WMZ	Digitalinput

relay allocation

relay 1	relay 2	relay 3	relay 4	relay 5	relay 6	relay 7
pump col. 1	pump col. 2	func.bl. 1 ext. HE	3 PV store 1-2	func.bl.3 HSE bypass par. relay	func.bl.4 store load	func.bl.5 message rel. AH suppress.

System 4 variant 2

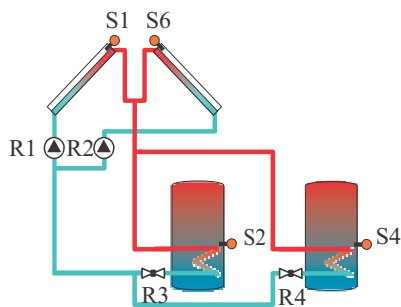

sensor allocation

sen.1	sen.2	sen.3	sen.4	sen.5	sen.6	sen.7	sen.8	sen.9	sen.10	V40	Din
Tcol	Tstb HSE	Tby	Tst2b	Th 5 T1-DT7	Tcol2 Th 6 T2-DT7	Th 7 T1-DT8	Th 8 T2-DT8	Th 9 T1-DT9 T1 WMZ	Th 10 T2-DT9 T2 WMZ	WMZ	Digitalinput

relay allocation

relay 1	relay 2	relay 3	relay 4	relay 5	relay 6	relay 7
pump col. 1	pump col. 2	2-PV store 1	2-PV store 2	func.bl.3 HSE bypass par. relay	func.bl.4 store load.	func.bl.5 message rel. AH suppress.

System 4 variant 3

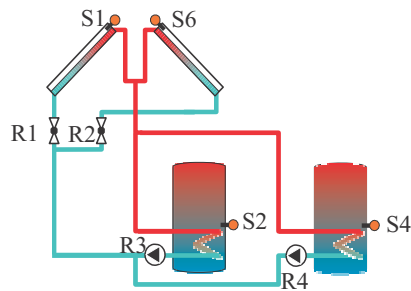

sensor allocation

sen.1	sen.2	Sen.3	sen.4	sen.5	sen.6	sen.7	sen.8	sen.9	sen.10	V40	Din
Tcol	Tstb HSE	Tby	Tst2b	Th 5 T1-DT7	Tcol2 Th 6 T2-DT7	Th 7 T1-DT8	Th 8 T2-DT8	Th 9 T1-DT9 T1 WMZ	Th 10 T2-DT9 T2 WMZ	WMZ	Digitalinput

relay allocation

relay 1	relay 2	relay 3	relay 4	relay 5	relay 6	relay 7
2-PV col. 1	2-PV col.2	solar pump st 1	solar pump st 2	func.bl.3 HSE bypass par. relay	func.bl.4 store load.	func.bl.5 message rel. AH suppress.

System 4 variant 4

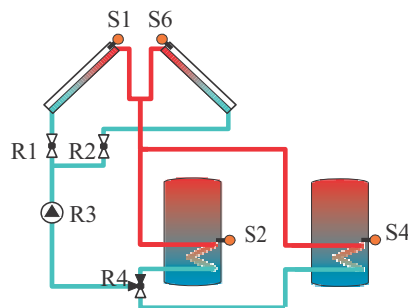

sensor allocation

sen.1	sen.2	sen.3	sen.4	sen.5	sen.6	sen.7	sen.8	sen.9	sen.10	V40	Din
Tcol	Tstb HSE	Tby	Tst2b	Th 5 T1-DT7	Tcol2 Th 6 T2-DT7	Th 7 T1-DT8	Th 8 T2-DT8	Th 9 T1-DT9 T1 WMZ	Th 10 T2-DT9 T2 WMZ	WMZ	Digitalinput

relay allocation

relay 1	relay 2	relay 3	relay 4	relay 5	relay 6	relay 7
2-PVKol.1	2-PVKol.2	solar pump	3 PV store 1-2	func.bl.3 HSE bypass par. relay	func.bl.4 store load.	func.bl.5 message rel. AH suppress.

System 5 variant 1

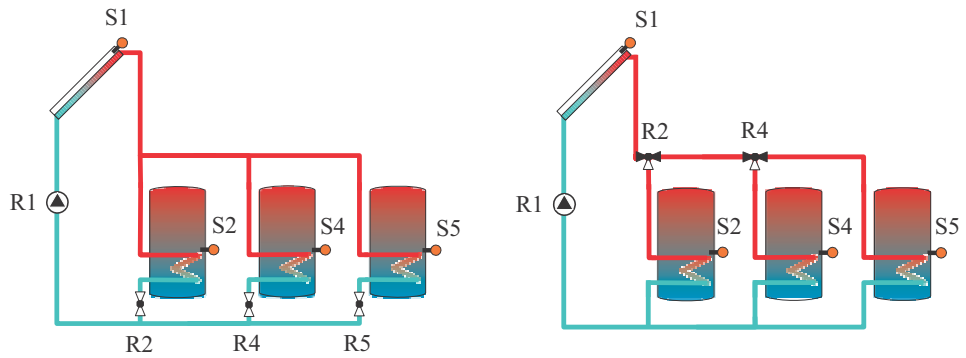

sensor allocation

sen.1	sen.2	sen.3	sen.4	sen.5	sen.6	sen.7	sen.8	sen.9	sen.10	V40	Din
Tcol	Tstb HSE	Th 1 Tby T-HE T1-DT5	Th 2 Tst2b T2-DT5	Tst3b	---	Th 7 T1-DT8	Th 8 T2-DT8	Th 9 T1-DT9 T1 WMZ	Th 10 T2-DT9 T2 WMZ	WMZ	Digitalinput

relay allocation

relay 1	relay 2	relay 3	relay 4	relay 5	relay6	relay 7
solar pump	2 PV store 1 (3PV store 1)	func.bl. 1 ext. HE	2 PV store 2 (3PV store 2)	2 PV store 3 (---)	func.bl. 4 store load. HSE bypass par. relay	func.bl. 5 message rel. AH suppress.

System 5 variant 2

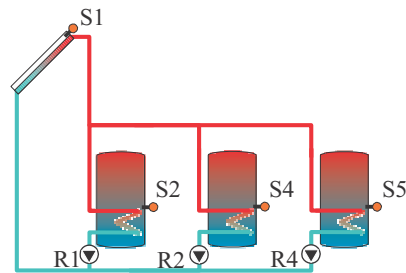

sensor allocation

sen.1	sen.2	sen.3	sen.4	sen.5	sen.6	sen.7	sen.8	sen.9	sen.10	V40	Din
Tcol	Tstb HSE	Th 1 Tby T-HE T1-DT5	Th 2 Tst2b T2-DT5	Th 5 Tst3b T1-DT7	Th 6 T2-DT7	Th 7 T1-DT8	Th 8 T2-DT8	Th 9 T1-DT9 T1 WMZ	Th 10 T2-DT9 T2 WMZ	WMZ	Digitalinput

relay allocation

relay 1	relay 2	relay 3	relay 4	relay 5	relay 6	relay 7
solar pump st1	solar pump st2	func.bl. 1 ext. HE	solar pump st 3	func.bl.3	func.bl.4 store load. HSE bypass par. relay	func.bl.5 message rel. AH suppress.

System 6 Variante 1

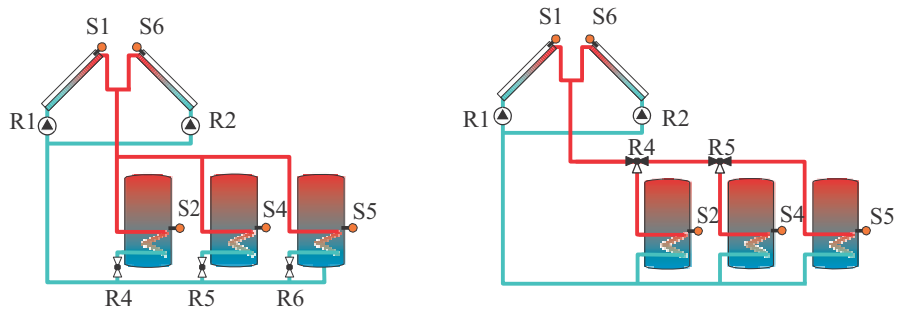

sensor allocation

sen.1	sen.2	sen.3	sen.4	sen.5	sen.6	sen.7	sen.8	sen.9	sen.10	V40	Din
Tcol	Tstb HSE	Th 1 T1-DT5 Tby T-HE	Th 2 T2-DT5 Tst2b	Tst3b	Tcol2	---	---	Th 9 T1-DT9 T1 WMZ	Th 10 T2-DT9 T2 WMZ	WMZ	Digitalinput

relay allocation

relay 1	relay 2	relay 3	relay 4	relay 5	relay 6	relay 7
pump col. 1	pump col. 2	func.bl. 1 HSE bypass par. relay ext. HE	2 PV store 1 (3 PV store 1)	2 PV store 2 (3 PV store 2)	2 PV store 3 (---)	func.bl.5 message rel. AH suppress.

System 6 variant 2

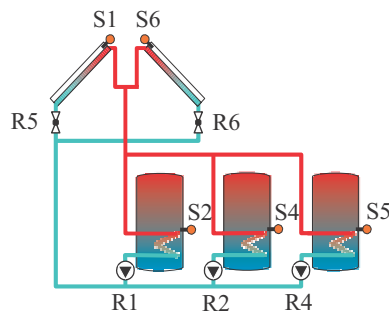

sensor allocation

sen.1	sen.2	sen.3	sen.4	sen.5	sen.6	sen.7	sen.8	sen.9	sen.10	V40	Din
Tcol	Tstb HSE	Th 1 Tby T-HE T1-DT5	Th 2 Tstp2b T2-DT5	Tst3b	Tcol2	---	---	Th 9 T1-DT9 T1 WMZ	Th 10 T2-DT9 T2 WMZ	WMZ	Digitalinput

relay allocation

relay 1	relay 2	relay 3	relay 4	relay 5	relay 6	relay 7
solar pump st1	solar pump st2	func.bl. 1 HSE bypass par. relay ext. HE	solar pump st3	2-PV col.1	2-PV col.2	func.bl.5 message rel. AH suppress.

System 6 variant 3

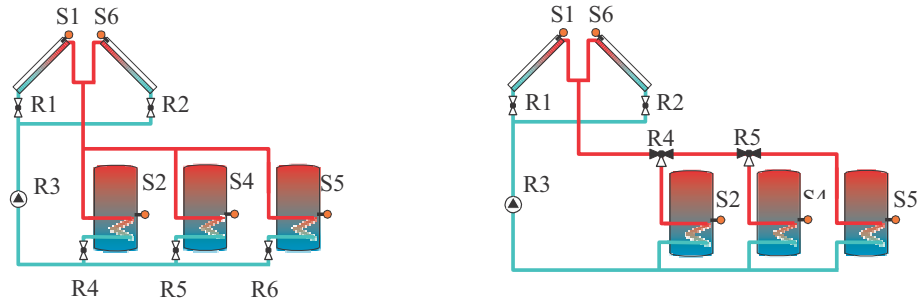

sensor allocation

sen.1	sen.2	sen.3	sen.4	sen.5	sen.6	sen.7	sen.8	sen.9	sen.10	V40	Din
Tkol	Tspu DVGW	---	Tsp2u	Tsp3u	Tkol2	---	---	Th 9 T1-DT9 T1 WMZ	Th 10 T2-DT9 T2 WMZ	WMZ	Digitalinput

relay allocation

relay 1	relay 2	relay 3	relay 4	relay 5	relay 6	relay 7
2-PV.col. 1	2-PV.col. 2	solar pump	2 PV store 1 (3 PV store 1)	2 PV store 2 (3 PV store 2)	2 PV store 3 (---)	func.bl.5 message rel. AH suppress.

System 7 variant 1

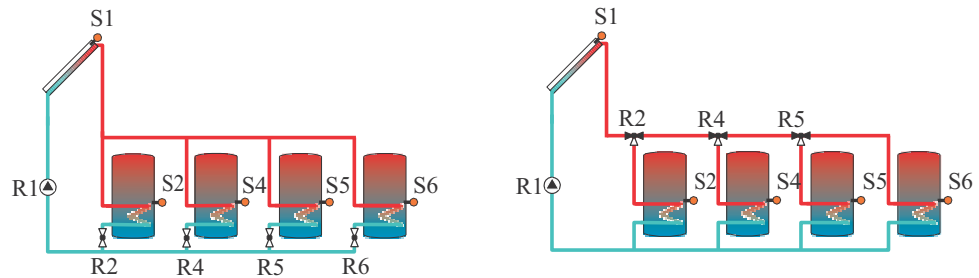

sensor allocation

sen.1	sen.2	sen.3	sen.4	sen.5	sen.6	sen.7	sen.8	sen.9	sen.10	V40	Din
Tcol	Tstb HSE	Th 1 Tby T-HE T1-DT5	Th 2 Tst2b T2-DT5	Tst3b	Tst4b	---	---	Th 9 T1-DT9 T1 WMZ	Th 10 T2-DT9 T2 WMZ	WMZ	Digitalinput

relay allocation

relay 1	relay 2	relay 3	relay 4	relay 5	relay 6	relay 7
solar pump	2 PV store 1 (3 PV store 1)	func.bl.1 HSE bypass par. relay ext. HE	2 PV store 2 (3 PV store 2)	2 PV store 3 (3 PV store 3)	2 PV store 4 (---)	func.bl.5 message rel. AH suppress.

System 7 variant 2

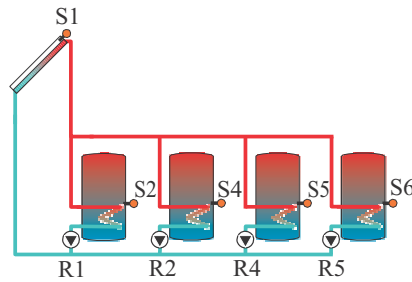

sensor allocation

sen.1	sen.2	sen.3	sen.4	sen.5	sen.6	sen.7	sen.8	sen.9	sen.10	V40	Din
Tcol	Tspu DVGW	Th 1 Tby T-WT T1DT5	Th 2 Tsp2u T2-DT5	Tsp3u	Tsp4u	Th 7 T1-DT8	Th 8 T2-DT8	Th 9 T1-DT9 T1 WMZ	Th 10 T2-DT9 T2 WMZ	WMZ	Digitalinput

relay allocation

relay 1	relay 2	relay 3	relay 4	relay 5	relay 6	relay 7
solar pump st1	solar pump st2	func.bl. 1 HSE bypass par. relay ext. HE	solar pump st3	solar pump st4	func.bl. 4 store load.	func.bl. 5 message rel. AH suppress.

Abbreviations - sensors

sensor	denomination
Tcol	temperature-collector
Tcol2	temperature-collector 2
Tstb	temperature-store 1 base
Tst2b	temperature-store 2 base
Tst3b	temperature-store 3 base
Tst4b	temperature-store 4 base
T-HE	temperature-heat exchanger
Tby	temperature-bypass
HSE	temperature- protection against legionella
Th 1-10	temperature-thermostat 1-10
T1-DT5-9	temperature- DT5-9 high
T2-DT5-9	temperature- DT5-9 low
T1-AH-HC	temperature- afterheating-heating circuit
T2-AH-HC	temperature- afterheating-heating circuit
HC T-FL	temperature- heating circuit flow
HC T-outd.	temperature- heating circuit outdoors
HC RTA11	heating circuit remote control
T1 WMZ	temperature- flow heat quantity measurement
T2 WMZ	temperature- return heat quantity measurement
WMZ	flowmeter
Digitalinput	message input

sensor	location
1	Solar Control
2	Solar Control
3	Solar Control
4	Solar Control
5	Solar Control
6	Solar Control
7	Solar Control
8	Solar Control
9	Solar Control
10	Solar Control
11	Flow HC
12	1. HKM(S1)
13	1. HKM(S2)
14	1. HKM(S3)
15	1. HKM(S4)
16	1. HKM(S5)

sensor	location
17	1. HKM(S6)
18	Flow 1. HKM
19	2. HKM(S1)
20	2. HKM(S2)
21	2. HKM(S3)
22	2. HKM(S4)
23	2. HKM(S5)
24	2. HKM(S6)
25	Flow 2. HKM
26	3. HKM(S1)
27	3. HKM(S2)
28	3. HKM(S3)
29	3. HKM(S4)
30	3. HKM(S5)
31	3. HKM(S6)
32	Flow 3. HKM

Sensor allocation

Sensors 1-10 are the sensors connected to the controller.
 Sensors 12-32 are the sensors connected to the additionally connected heating circuit modules.
 Sensors 11, 17, 25 and 32 show the calculated flow set temperature respectively.

Abbreviations - relay

relay	denomination
pump col.1 (2)	solar pump collector field 1-2
Solar Pumpe Sp 1-4	solar pump store 1-4
2 PV St 1-4	2-port valvestore 1-4
3 PV St 1-3	3-port valvelstore 1-3
func.bl. 1-5	function block 1-5
HSE	protetion against legionella
bypass	bypass-circuit
cooling func.	cooling function
store load.	store loading
par. relay	parallel relay
ext. HE	external heat exchanger
message rel.	message relay
AH suppress.	afterheating suppression
HC-afterheat.	heating circuit afterheating
HC-pump	heating circuit pump
HC-Mi open	heating circuit mixer open
HC-Mi closed	heating circuit mixer closed

4. Functions and options

4.1 Menu: Solar

System:

Solar/Options/System

adjustment range: 1 ...7

factory setting: 1

Select the appropriate basic system (see 3.2).

Note:

Select the basic system first, because the subsequent selection of a new system will reset all other adjustments to the factory settings.

Hydraulic variants:

Solar/Options/loading

adjustment range: 1 ...4

factory setting::1

Many hydraulic variants distinguish between pump and valve control e.g. for multiple stores. The adjustment has to be carried out in accordance with the overview of the basic systems with their hydraulic variants (see 3.2).Broadly speaking, variants with pumps allow speed control, variants with valves do not and will automatically set the minimum speed to 100%.

Schematic:

Solar/Options/schematic

adjustment range: 000 ...030

factory setting: 000

Alternatively to the basic system and hydraulic variant, one of the 30 pre-programmed schemes can be selected.

If a new scheme is selected subsequently, all other adjustments will be reset to the factory settings!.

Bypass:

Solar/Options/Bypass

selection: „Yes“, „No“

factory setting: „No“

In order to prevent energy from being extracted from the store when starting store loading, this function makes sure that the cold fluid in the pipes is diverted past the store via a bypass (valve or pump). Once the pipe is warm enough, the store can be loaded.

The bypass relay is energised if the temperature at the reference sensor is by 2,5 K higher than the store temperature and if the switch-on condition for store loading (see store loading) is fulfilled. The relay is switched-off if this temperature difference is lower than 1,5 K. These temperature differences cannot be adjusted.

Variant valve or bypass

Solar/Expert/Bypass

selection: „Valve“, „Pump“

factory setting: „Valve“

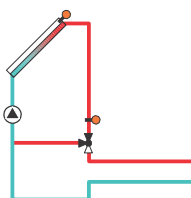
Variant valve:

A bypass valve is placed into the solar circuit.

The solar heat exchanger is first bypassed when store loading is possible. If the above-mentioned switch-on condition is fulfilled, the bypass relay switches the collector circuit via the heat exchanger.

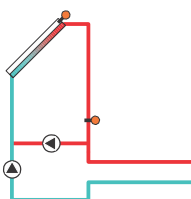
Variant pump:

In this version, a bypass pump is placed in front of the collector pump.

The bypass pump is first activated when store loading is possible. If the above-mentioned switch-on condition is fulfilled, the bypass pump is switched-off and the collector circuit pump is activated.

This variant is available in 1-collector systems only.

Bypass sensor:

Solar/Expert/Sen. Bypass

adjustment range: 1 ... 10

factory setting: 3

The reference sensor is located in front of the valve or the pump respectively. The default is sensor 3, but this can be changed using this menu item.

External heat exchanger:

Solar/Options/Ext. heat. ex.

selection: „Yes“, „No“

factory setting: „No“

Solar/adj. values/he DTon

adjustment range: 2,0 ... 19,5 K

factory setting: 5,0 K

Solar/adj. values/he DToff

adjustment range: 1,5 ... 19,0 K

factory setting: 3,0 K

Solar/Expert/Sen. Ext. HE

adjustment range: 1 ... 10

factory setting: 3

This function is used to link loading circuits that are separated by an external heat exchanger.

The heat exchanger relay is activated if the temperature at the reference sensor exceeds the store temperature by the adjusted value "HE DTon" and if the switch-on conditions for store loading (see "store loading") are fulfilled.

The relay is switched-off if this temperature difference falls below the adjusted switch-off difference HE-DToff.

In contrast to the bypass function, a differential regulation between "T-HE" ("Sen. Ext. HE") and "Tst" can be carried out by means of the heat exchanger relay.

The reference sensor ("Sen. Ext. HE") can be arbitrarily allocated.

In systems in which stores are equipped with their own loading pumps, the relay "external heat exchanger" controls the primary circuit pump.

Tube collector function:

Solar/Options/Rtube col.

selection: „Yes“, „No“

factory setting: „No“

Solar/Expert/tube-run

adjustment range: 5 ...500 s

factory setting: 30 s

Solar/Expert/tube-init

adjustment range: 00:00 ...00:00

factory setting: 07:00

Solar/Expert/tube-final

adjustment range: 00:00 ...00:00

factory setting: 19:00

Solar/adj. values/tube col

adjustment range: 1 ...60 min

factory setting: 30 min

This function helps overcome the non-ideal sensor position with some tube collectors.

This function operates within a given time frame (“tube init“ and “tube-final“). It activates the collector circuit pump for 30 seconds (adjustable via the parameter “tube-run“) every 30 minutes (adjustable via the parameter “tube col“) in order to compensate for the delayed temperature measurement.

If the collector sensor is defective or the collector is blocked, this function is suppressed or switched-off.

The collector circuit is operated at minimum pump speed.

2-collector systems**2 separate collector circuits (2 pumps)**

Both collectors are operated independently from each other by means of this function.

If a store is being loaded by one collector, the other one is nevertheless operated after the adjusted standstill time.

shared collector circuit (1 pump)

If store loading is carried out by one collector, the other one is nevertheless operated after the adjusted standstill time.

This means the pump speed may reduce briefly to the minimum as the normal pump speed is ignored by the controller.

Cooling function (1-store systems):

Solar/Options/cool func.

selection: „Yes“, „No“

factory setting: „No“

The cooling function can be used in 1-store systems (basic systems 1 and 2). If the store temperature exceeds its maximum limitation (Tstmax), the surplus energy in the collector can be diverted. The pump output uses maximum pump speed.

Function (switching conditions):

If Tstmax is exceeded, and the switch-on temperature difference DTon between collector and store are reached, the solar circuit (primary) and the cooling relay are operated.

If the switch-off temperature difference DToff is underrun during this period, the solar circuit and the cooling relay are switched-off.

**2-collector system:
(basic system 2)**

In this system, only the collector circuit which fulfills the switch-on conditions described above, is operated.

Collector cooling function:

Solar/Options/col. cooling

selection: „Yes“, „No“

factory setting: „No“

if you select „Yes“:

Solar/adj. values/Tcolmax

adjustment range: 80 ... 160 °C

factory setting: 110 °C

hysteresis 5 K

The collector cooling function starts, when the adjusted maximum collector temperature is reached. If this temperature is underrun by 5 K, this function is switched off.

The collector is cooled via the heat transfer to the next free store (a store which is not blocked). The numerically last store is not used (swimmingpool protection or in the case of multi-store systems).

The pump output (provided that the function is active) is controlled with maximum relative pump speed.

Note:

It is not possible to adjust a temperature value for the maximum collector temperature (Tcolmax) which is higher than the collector emergency shutdown temperature. There must be a difference between these two temperatures of at least 10 K.

2-collector systems:**2 separated collector circuits (2 pumps):**

The collector circuit which needs to be cooled is operated. If one store is being loaded by another collector, this loading is continued.

shared collector circuit (1 pump):

“Pump speed“ depends on collector cooling which takes priority.

Recooling:

Solar/Options/recooling

selection: „Yes“, „No“

factory setting: „No“

This function is used for keeping the system temperatures and consequently the thermal load as low as possible.

If the temperatures of all stores of the system have exceeded the maximum temperature, the Tstmax for the first store is temporarily overridden to reduce the surplus energy via the pipework and the collector. Note Tstmax may be exceeded so additional scald protection may be required.

This “circulation“ is switched-off once the maximum store temperature is underrun by 2 K.

2-collector systems:

Both collector circuits are activated in a 2-collector system.

Combination with collector cooling function:

If the option “collector cooling“ is activated in addition to the recooling function, the behaviour of the recooling function changes.

The objective is now to dissipate the energy supplied by collector cooling.

If the temperature at the collector decreases by 5 K below that of the store, the recooling function becomes active and the loading circuit is again operated to cool the store.

If the difference between collector and store decreases below 3 K during that cooling period, the function is switched-off.

2-collector system:

In a 2-collector system, the collectors are operated separately, using the switch-on conditions described above.

Frost protection:

Solar/Options/Frost prot.

selection: „Yes“, „No“

factory setting: „No“

As soon as the temperature at the collector is 4 °C, the frost protection function operates the loading circuit between the collector and the 1st store in order to protect the medium in the loading circuit against freezing or coagulation.

If the collector temperature exceeds 5 °C, this function is switched-off.

If the 1st store in the system is blocked, this function is switched off or suppressed.

The pump output uses maximum pump speed.

2-collector system:

In these systems, the circuit which fulfills the switch-on condition described above is operated.

Target temperature:

Solar/Options/Target tem.

selection „Yes“, „No“

factory setting: „No“

if you select „Yes“.

Pump speed is controlled according to collector temperature rather than (usual) temperature difference. The aim is to maintain constant collector temperature, adjustable with parameter „Tcolset“.

Solar/adj. values/tcolset

adjustment range: 20 ...110 °C

factory setting: 65 °C

Parallel relay:

Solar/Options/Par. Relay

selection: „Yes“, „No“

factory setting: „No“

If the solar circuit pump is switched-on, this relay is activated in parallel.

In 2-collector systems which are working with 2 pumps, the parallel relay is activated if one of the 2 pumps is activated.

CS-Bypass:

Solar/Options/CS-Bypass

selection: „Yes“, „No“

factory setting: „No“

if you select „Yes“:

If the irradiation exceeds the adjusted value CS-bypass, the collector circuit is operated. It is switched off when the irradiation has fallen below the value „CS-bypass“ for at least 2 minutes.

The collector circuit is operated with minimum pump speed.

Solar/adj. values/CS-Byp

adjustment range: 100 ...500 W/m²factory setting: 200 W/m²**2-collector systems:**

If a loading of the store is carried out in these systems, the function is switched-off.

Afterheating suppression:

Solar/Options/ah suppress.

selection: „Yes“, „No“

factory setting: „No“

if you select „Yes“:

This function is active if a previously selected solar store (parameter designation: „AH suppress.“ in the menu solar expert) is being loaded.

Solar loading means that store loading is only carried out for energy supply and not for cooling purposes etc.

Solar/Expert/ah suppress.

adjustment range: St 1 ...St 4

factory setting: St 1

Collector emergency shutdown:

Solar/adj. values/Tcolsec

adjustment range: 110 ... 200 °C

factory setting: 130 °C

hysteresis: 10K

At high collector temperatures (depending on system pressure or antifreeze concentration etc.) the systems stagnates. This means that solar loading is not possible.

If the adjusted temperature threshold „Tcolsec“ is exceeded, the corresponding collector will no longer be used for loading.

collector blocked

A collector is considered to be blocked, if either the sensor is defective or the emergency shutdown temperature is reached.

Collector minimum limitation:

Solar/Expert/Tcolmin

adjustment range: -25 ... 90 °C

factory setting: 10 °C

hysteresis 2 K

This is the minimum temperature which must be exceeded for the solar pump to switch on. If the adjusted minimum temperature is not exceeded or the condition "collector blocked" is fulfilled.

St2on ...St4on:

Solar/Options/St2 on (... St4 on)

selection: „Yes“, „No“

factory setting: „Yes“

By means of this function, the respective store can be "removed" from solar control. This means that it is no longer considered for solar loading.

The temperature of the store will be indicated but a sensor defect will not be recognised.

Store loading:

Solar/adj. values/DTon (...DT4on)

adjustment range: 1,0 ... 20,0 K

factory setting: 5,0 K

If the adjusted switch-on difference DTon between collector and store is exceeded, the store will be loaded.

If this difference falls below the adjusted switch-off difference DToff, the loading function will be switched off.

Solar/adj. values/DToff (...DT4off)

adjustment range: 0,5 ... 19,5 K

factory setting: 3,0 K

Loading of the store will also be switched-off or suppressed if the relevant store or collector is blocked (collector blocked, see collector minimum limitation) or if the store is at maximum limitation.

Solar/adj. values/DTset (...DT4set)

adjustment range: 2,0 ... 30,0 K

factory setting: 10,0 K

The parameter "DTset" is the nominal temperature difference between collector and store used for pump speed control. Once DTset is reached, the pump speed is increased by 10 %.

Store maximum limitation:

Solar/adj. values/Tstmax (...Tst4max)

adjustment range: 4 ... 95 °C

factory setting: 60 °C

If the adjusted maximum temperature Tstmax is exceeded, loading of the store is stopped. If the store cools down by more than 2 K (hysteresis), the store will be loaded again.

Hysteresis

Solar/Expert/DT-Stmax (...DT-St4max)

adjustment range: 0,5 ... 5,0 K

factory setting: 2,0 K

store emergency shutdown

value 95 °C

hysteresis = 2 K

If the cooling options are activated (e.g. collector cooling), the store will be loaded beyond the adjusted maximum temperature.

In order to avoid too high temperatures in the store, the emergency shutdown of the store is additionally provided, which also blocks the store for the cooling options. If a store reaches the temperature of 95 °C, the emergency shutdown is active.

store blocked

A store is blocked if either the corresponding sensor is defective or the emergency shutdown temperature has been reached.

Priority logic and store sequence control:**Solar/adj. values/priority St1 (...St4)**

adjustment range: 1 ...4

factory setting: 1; 2; 3; 4

Priority logic is used in multi-store systems only.

If St1, St2, St3, St4 are set to 1, the stores with a temperature difference to the collector are loaded in parallel as long as their switch-on conditions are fulfilled.

If St1 is set to 1, St2 to 2, St3 to 3, and St4 to 4 (factory setting) the first store will be loaded first as long as its switch-on conditions are fulfilled. When the selected priority store reaches its adjusted maximum temperature, the subordinate stores will be loaded in numerical order via oscillating loading: store 1, then store 2, then store 3, then store 4.

Store sequence control:**Solar/Expert/t-circ.**

adjustment range: 1 ... 60 min

factory setting: 15 min

The controller checks whether the stores can be loaded (switch-on difference).

When the priority store cannot be loaded, the subordinate stores are checked. If a subordinate store can be loaded, it will be loaded for the "oscillating loading time" ("t-circ."). After this period of time, the loading process stops. The controller monitors the increase in collector temperature. If it increases by the "collector rise temperature" (DT-col) within the loading break time "t-st", the elapsed break time is set to 0. The break time starts again.

Loading break time:**Solar/Expert/t-st**

adjustment range: 1 ... 60 min

factory setting: 2 min

As soon as the switch-on condition of the priority store is fulfilled, it will be loaded. If the switch-on condition of the priority store is not fulfilled, loading of the subordinate stores will be continued. If the priority store reaches its maximum temperature, oscillating loading will not be carried out.

Collector rise temperature:**Solar/Expert/DT-col**

adjustment range: 1 ... 10 K

factory setting: 2 K

The controller has integrated registers which record the following values:

- maximum temperatures
- operating hours of the relays
- operating days since commissioning of the controller

The values can be reset, except for "operating days".

Balancing functions:**Solar/Balance values****4.2 Menu: Arrangement****HSE (protection against legionella):****Arrangement/Options/HSE**

selection: „Yes“, „No“ factory setting:

„No“ Arrangement/adj. values/t-

start adjustment range: 00:00 ... 00:00

factory setting: 17:00

Arrangement/Expert/Sen-hse

adjustment range: 1 ... 10

factory setting: 2

The HSE-function checks whether the temperature at the given sensor (Sen-HSE) exceeds 60 °C at certain times for legionella control.

If 60 °C has not been achieved by the HSE start time, the HSE relay is energised in order to activate e.g. afterheating. The HSE start time (t-start) is adjustable.

The relay is switched-off once 60 °C is reached at the relevant sensor (factory setting 2 - selectable) or at midnight (reset point).

If the relevant sensor is defective, this function is suspended.

Store loading:

Arrangement/Options/store load.

selection: „Yes“, „No“ factory setting:

„No“ Arrangement/adj.

values/Th7on adjustment range: -

40,0 ...250,0 °C

factory setting: 40,0 °C

Arrangement/adj. values/Th7off

adjustment range: -40,0 ...250,0 °C

factory setting: 45,0 °C

Arrangement/Expert/Sen-Th7

adjustment range: 1 ...10

factory setting: 7

Arrangement/Expert/Sen-Th8

adjustment range: 1 ...10

factory setting: 8

Arrangement/Options/timer 4

selection: „Yes“, „No“ factory setting: „No“

Arrangement/Einstellwerte/timer2/t1(...21)-on

adjustment range: 00:00 ...00:00

factory setting: 22:00

Arrangement/adj. values/timer2/t1(...21)-off

adjustment range: 00:00 ...00:00

factory setting: 05:00

Function blocks:

Arrangement/Options/Thermo.1 (...10)

selection: „Yes“, „No“ factory setting:

„No“ Arrangement/Options/DT-Func

(...9) selection: „Yes“, „No“

factory setting: „No“

Arrangement/Options/timer 1 (...5)

selection: „Yes“, „No“

factory setting: „No“

Arrangement/Expert/Sen-Th1 (...10)

Arrangement/Expert/Sen1-DT5(...9)

Arrangement/Expert/Sen2-DT5(...9)

In order to carry out afterheating of a store within a certain store volume (store zone), this function uses 2 sensors to monitor the switch-on and switch-off level.

The switch-on and -off temperatures Th7on and Th7off are used as reference parameters.

Adjust the reference sensors via Sen-Th7 and Sen-Th8.

If the measured temperatures at both reference sensors fall below the adjusted switching threshold Th7on, the relay is switched-on. It is switched-off if the temperature at both sensors is higher than Th7off.

If one of the two sensors is defective, store loading is suppressed or switched off.

In addition to the above, a timeswitch can be set to temporarily block operation in 21 time frames (3 for each day) by means of the dailytimer 4.

Depending on the selected basic system and activated options, there are up to 5 function blocks including thermostat functions, timer and differential functions. With these, further components or functions e.g. solid fuel boiler, heating backup and DHW afterheating can be implemented (see 3.3 for further examples).

Function blocks are assigned to the relays (see 3.5) and the relay cannot be changed. Each function block has allocated sensors that can be changed in the expert menu if needed. It is also possible to „double up“ in the programming and use a sensor already allocated to another function.

Within a function block the functions are interconnected (AND gate). This means that the conditions of all the activated functions have to be fulfilled for switching the allocated relay. As soon as one condition is not fulfilled, the relay is switched off.

Thermostat function**(Function block 1...5):**

Arrangement/Options/Thermo1 (...10)

selection: „Yes“, „No“

factory setting: „No“

Arrangement/adj. values/Th1(...10)on

adjustment range: - 40,0 ...250,0 °C

factory setting: 40,0 °C

Arrangement/adj. values/Th1(...10)off

adjustment range: - 40,0 ...250,0 °C

factory setting: 45,0 °C

Arrangement/Expert/Sen-Th1 (...10)

adjustment range: 1 ...10

factory setting: 3 (...10)

DT-function (function block 1...5):

Arrangement/Options/DT-func 5 (...9)

selection: „Yes“, „No“

factory setting: „No“

Arrangement/adj. values/DT5(...9)on

adjustment range: 1,0 ...50,0 K

factory setting: 5,0 K

Arrangement/adj. values/DT5(...9)off

adjustment range: 0,5 ...50,0 K

factory setting: 3,0 K

Arrangement/Expert/Sen 1-DT5(...9)

adjustment range: 1 ...10 factory setting: 3

(...10)Arrangement/Expert/Sen 2-

DT5(...9) adjustment range: 1 ...10

factory setting: 4 (...10)

Timer function (function block 1...5):

Arrangement/Options/timer 1 (...5)

selection: „Yes“, „No“

factory setting: „No“

Arrangement/adj. values/timer 1 (...5)/t1(...21)-on

adjustment range: 00:00 ...00:00

factory setting: 22:00

Arrangement/adj. values/timer 1 (...5)/t1(...21)-

off

adjustment range: 00:00 ...00:00

factory setting: 05:00

The relay allocated to the function block is switched on, when the adjusted switch-on temperature (Th(x)on) is reached. It is switched off when the adjusted switch-off temperature (Th(x)off) is reached. The switching conditions of all other activated functions of the function block have to be fulfilled as well.

Allocate the reference sensor in the expert menu.

Adjust the maximum temperature limitation with Th(x)off > Th(x)on and the minimum temperature limitation with Th(x)on > Th(x)off. The temperatures cannot be set to an identical value.

The relay allocated to the function block is switched on as soon as the adjusted switch-on temperature (DTh(x)on) is reached. It is switched off as soon as the adjusted switch-off temperature (DTh(x)off) is reached. The switching conditions of all other activated functions of the function block have to be fulfilled as well.

Adjust the reference sensor in the expert menu.

Each timer function provides up to 21 time frames (3 for each day). The relay allocated to the function block is activated as long as the time frame (t(x)on ... t(x)off) is open. The switching conditions of all other activated functions of the function block have to be fulfilled as well.

4.2.1 Heating circuits:

Internal heating circuit control:

Arrangement/heat circuit/Options/hc

selection: „Yes“, „No“

factory setting: „No“

Flow temperature

Arrangement/heat circuit/HC/Tflow

Outdoor temperature

Arrangement/heat circuit/HC/Toutd

Status heating circuit

Arrangement/heat circuit/hc/Hc Stat

Set flow temperature

Arrangement/heat circuit/hc/flow set

Status afterheating

Arrangement/Heat circuit/hc/afterh.

Store temperature 1 (2)

Arrangement/Heat circuit/hc/T(2)st

Night correction:

Arrangement/Heat circuit/hc/night corr.

adjustment range: -20...+30 K

factory setting: -5 K

Day correction:

Arrangement/Heat circuit/hc/day corr.

adjustment range: -5...+45 K

factory setting: 5 K

Maximum flow temperature:

Arrangement/Heat circuit/hc/Tflowmax

adjustment range: 10...+100°C

factory setting: 50°C

The controller can control up to 4 independent weather-compensated heating circuits. One heating circuit can be controlled via the internal control functions and the others via an additional external module HKM2 each.

The internal heating circuit is activated in this menu.

The TFlow-value indicates the measured actual flow temperature of the heating circuit.

The Temperature-outdoor-value indicates the measured outdoor temperature depending on weather conditions.

Display of heating circuit status (summer, day, night, defect).

The flow set temperature is calculated from the measured outdoor temperature and the heating curve. Onto this, the dial setting of the remote control (RTA11-M) and the controller day correction or night correction are added.

Flow set temperature = heating curve temperature + remote control + (day correction or night correction). If the calculated flow set temperature is higher than the adjusted maximum flow temperature, the flow set temperature will be equated with the maximum flow temperature.

Display of afterheating status (on, off).

Display of store temperature(s) of the heating circuit afterheating.

Adjustment channel for night correction (night set back) of the heating circuit. For the night correction function, time frames (see below) can be adjusted. Within these timeframes, the set flow temperature of the curve will be decreased (set back) by the adjusted temperature value.

Adjustment channel for the day correction function of the heating circuit. The day correction function is always active **outside** the 3 time frames of the night correction function. The flow set temperature of the curve will be decreased or increased by the adjusted temperature value.

Adjustment channel for the admissible maximum flow temperature of the heating circuit. If the maximum flow temperature is exceeded, the heating circuit will be switched off (the mixer will close).

Heating curve:

Arrangement/Heat. circuit/hc/heat. curve

adjustment range: 0,3...3,0

factory setting: 1,0

The heating curve used by the controller can be increased or decreased to suit the building heating load as shown in the family of curves below. Increasing this value has the effect of raising the flow set temperature, reducing the value will lower the flow set temperature.

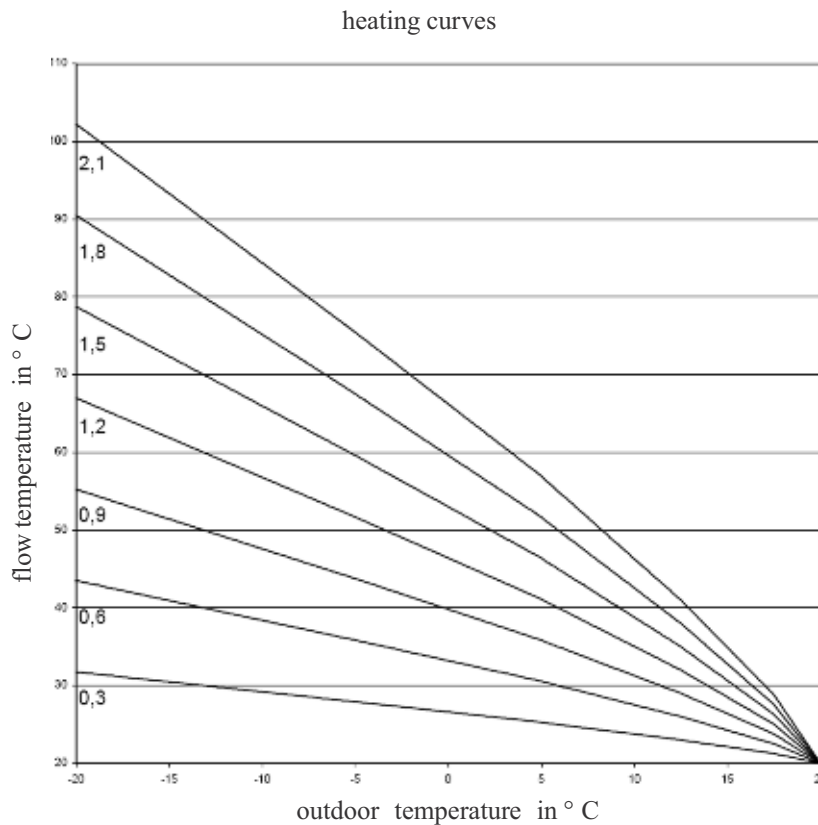

Mixer:

Arrangement/Heat. circuit/hc/mixer

adjustment range: 1 ...20s

factory setting: 4 s

The mixer function controls the mixing valve position according to the difference between the actual flow temperature and the set flow temperature. The valve is opened or closed in pulses depending on this deviation. The parameter „mixer“ allows the pulse operating time to be matched to suit the valve operating time.

Sommer:

Arrangement/Heat. circuit/hc/summer

adjustment range: 0 ...40°C

factory setting: 20 °C

Adjustment channel for summer operation. If the outdoor temperature exceeds the adjusted value, the heating circuit will be switched off. The hysteresis is 1,0 K.

Timer:

Arrangement/Heat.circuit/hc/timer/Mode

selection: "Night / Day", "Off / Day", "Without"

factory setting: "Night / Day"

Arrangement/Heat.circuit/hc/timer/t1(...21)-on

adjustment range: 00:00 ... 00:00

factory setting: 22:00 (t1...t7-on)

Arrangement/Heat.circuit/hc/timer/t1(...21)-off

adjustment range: 00:00 ... 00:00

factory setting: 05:00 (t1 ...t7-off)

Example: The night correction runs from Monday to Tuesday from 22:00 to 6:00 and Tuesday from 15:00 to 18:00, when t1-on is set to mon 22:00, t1-off to tue,6:00 and t2-on to tue,15:00 and t2-off to tue,18:00.

Flow sensor:

Arrangement/Heat.circuit/hc/Expert/Sen.flow

adjustment range: 1 ... 10

factory setting: 6

Outdoor temperature sensor:

Arrangement/Heat.circuit/hc/Expert/Sen.outdoor

adjustment range: 1 ... 10

factory setting: sensor 7

Afterheating

Arrangement/Heat.circuit/hc/Expert/aft.-heat

selection: „None“, „Therm.“, „Store“

factory setting: „None“

The timer determines whether day correction or night correction (set back) is used for changing the set flow temperature. 21 different time frames (3 for each day) can be set for night correction of the heating circuit.

If one of the time frames is set to 'active', night correction will be active.

If none of them is active, the set flow temperature will be adapted with day correction. The timers are pre-allocated such that every day from 10:00 pm to 5:00 am (the following day) night set back is active.

The **mode** determines the operation mode of the timer:

Night/ day time frame for night correction

off / day time frame for heating circuit off

without timer deactivated

Adjustment channel for allocating the sensor in flow.

The default is sensor 6 – this can be reallocated if needed. A sensor which is already in use can be allocated without influencing its original function in the system.

Adjustment channel for allocating the outdoor temperature sensor.

The default is sensor 7 – this can be reallocated if needed. A sensor which is already in use can be allocated without influencing its original function in the system.

Note:

If additional external modules HKM2 are used, only 1 outdoor temperature sensor is required. In order to ensure that all heating circuits use the same outdoor temperature, adjust to sensor 13.

The set flow temperature is compared with the temperature at one or two store (buffer) reference sensors (differential control). If this temperature differential is too small (DTHon), afterheating will be activated. It will be switched off, if the differential (DTHoff) between store and set flow temperature is large enough.

Arrangement/Heat circuit/hc/Expert/DT ah on
 adjustment range: -15,0 ... 49,5 K
 factory setting: 4,0 K

Arrangement/Heat circuit/hc/Expert/DT ah off
 adjustment range: -14,5 ... 50,0 K
 factory setting: 14,0 K

Sensor 1 store

Arrangement/Heat circuit/hc/Expert/S1 Store
 adjustment range: 1 ... 10
 factory setting: 4

Sensor 2 store

Arrangement/Heat circuit/hc/Expert/S2 store
 adjustment range: 1 ... 10
 factory setting: 5

Afterheating demand

Arrangement/Heat circuit/hc/Expert/rel. ah off
 selection: „DSE“, „HC1“, „HC2“, „HC3“
 factory setting: „DSE“

Arrangement/Heat circuit/hc/Expert/ah-Min.
 adjustment range: 0 ... 90 min
 factory setting: 0 min

Arrangement/Heat circuit/hc/Expert/ah
 adjustment range: 0 ... 1000 s
 factory setting: 0 s

Manual correction (remote control)

Arrangement/Heat circuit/hc/Expert/man. corr.
 selection: „Yes“, „No“
 factory setting: „No“

Sensor remote control

Arrangement/Heat circuit/hc/Expert/Sen. remote
 adjustment range: 1 ... 10
 factory setting: 8

Chimney sweeper

Arrangement/Heat circuit/hc/Expert/chimney
 selection: „Yes“, „No“
 factory setting: „No“

Select the after-heating type via the parameter “Aft.-Heat.” (“None“, “Therm.“, or “Store“).

If “None“ is selected, no afterheating will be carried out.

If “Therm.“ is selected, the set flow temperature is compared with a store reference sensor.

If “Store“ is selected, the comparison is made with 2 reference sensors. The switching conditions to both reference sensors have to be fulfilled.

With this parameter, the 1st reference sensor for heating circuit afterheating can be selected.

With this parameter, the 2nd reference sensor can be selected for store-dependent afterheating.

Select the relay by means of which afterheating is demanded (DSE or heating circuit module).

Allocate minimum runtime and overrun time of the relay.

The remote control (RTA11-M) allows manual adjustment of the heating curve (± 15 K). The remote control is optional and it is not included in the full kit.

The heating circuit can be switched off manually, if the remote control is set to the position “heating circuit off“. Heating circuit switched-off means that the heating circuit pump is switched off and the mixer closed.

Flow temperature is boosted to maximum for rapid heating when the remote control it is set to “rapid heating“.

Adjustment channel for allocating the remote control sensor. The factory setting is sensor 8.

When this option is activated, the heating circuit opens (mixer opens) and the heating circuit pump is switched-on (provided that the chimney sweeper function is active, see 4.4). The protective function of the heating pump maximum limitation will still be active.

External heating module:

Heating circuit module

Arrangement/Heat circuit/Options/Hc1(2,3)Module

selection: "Yes", "No"

factory setting: "No"

Arrangement/Heat circuit/hc/Expert/Sen. outdoor

adjustment range: 1 ... 17

factory setting: 7

change to: 13

Up to 3 additional external heating circuit modules (HKM) can be activated if further compensated heating circuits are required.

If the external heating circuit module HKM2 is additionally used, only 1 outdoor temperature sensor is required.

In order to ensure that all heating circuits control using the same outdoor temperature, adjust to sensor 13 and connect the external sensor to the HKM module.

Store priority:

Arrangement/heat circuit/hc1(2,3)module/store prio.

selection: "On", "Off"

factory setting: "Off"

This function switches off the heating circuit when domestic hot water is being afterheated.

For this purpose, the option domestic hot water priority and afterheating via store loading (see 4.2) of the controller Solar Control 3020 have to be active as well.

Arrangement/heat circuit/Hc-Module/...

The displays and functions are comparable to those of the internal heating circuit (see also manual „HKM 2“).

4.3 Menu: Heat quantity measurement

WMZ/Options/WMZ (WMZ-Module)

selection: "Yes", "No"

factory setting: "No"

WMZ/WMZ 1/ Expert/flowmeter

selection: "Yes", "No"

factory setting: "No"

WMZ/WMZ 1/Expert/Sen. flow

adjustment range: 1 ... 10

factory setting: 9

WMZ/WMZ 1/Expert/Sen. return

adjustment range: 1 ... 10

factory setting: 10

The controller has a separate integrated calorimeter which can be configured with or without flowmeter V40. Furthermore, the values of a separate WMZ module can be displayed.

Allocate the sensors. Factory settings are as shown – but other sensors can be allocated without influencing their original function in the system.

Heat quantity measurement without flowmeter V40

Set WMZ/Options/WMZ to „Yes“ and

WMZ/WMZ 1/Expert/flowmeter to

„No“ WMZ/WMZ1/Expert/flow

adjustment range: 1,0 ... 50,0 l

factory setting: 3,0 l

WMZ/WMZ 1/Expert/Relay

adjustment range: 1 ... 7

factory setting: 1

The heat quantity measurement calculation (estimation) uses the difference between flow and return temperature and the user entered flow rate. The flow rate should be read from the window of the flow setter at 100 % pump speed. Heat quantity measurement is carried out when the output selected in the "relay" menu is active.

Heat quantity measurement with flowmeter V40

Set WMZ/Options/WMZ to „Yes“ and
 WMZ/WMZ 1/Expert/flowmeter to „Yes“
 WMZ/WMZ 1/Expert/Vol./puls.
 adjustment range: 0,5 ... 99,5 (liter/pulse)
 factory setting: 1 (liter/pulse)

The heat quantity measurement calculation uses the difference between flow and return temperature and the volume flow transmitted by the flowmeter.

Adjust the pulse rate corresponding to the flowmeter V40 used (see the flagon the V40 cable):

V40-06: 1 litre/pulse
 V40-15: 10 litres/pulse
 others: 25 litres/pulse

Antifreeze type

WMZ/WMZ 1/Expert/antifreeze type
 selection: 0,1,2,3
 factory setting: 1

Adjustment channel to ensure the controller uses the correct specific heat capacity for the heat transfer fluid used .

0 for water
 1 for propylene glycol
 2 for ethylene glycol
 3 for Tyfocor® LS

Antifreeze

WMZ/WMZ 1/Experte/antifreeze
 adjustment range: 20 ... 70 Vol %
 factory setting: 40 Vol %

Adjustment channel for the concentration water/ glycol for antifreeze types 1 and 2.

Heat quantity

WMZ/WMZ

The overall heat quantity results from the sum of the values in Wh, kWh and MWh.

The different values can be reset to 0. To reset, select the desired value and answer the security prompt “Save?” with “No”.

4.4 Menu: Expert

System warning “DT too high“

Expert/DT too high
 selection: „Yes“, „No“
 factory setting: „Yes“

This message is shown, if solar loading has been carried out for a period of 20 minutes with a differential higher than 50 K.

The message function can be deactivated by selecting “No”.

System warning “Non-ret. valve“

Expert/non-ret. val.
 selection: „Yes“, „No“
 factory setting: „Yes“

This message is shown if between 11 p.m. and 5.00 a.m. the collector temperature is higher than 40 °C or a store is loaded because of a high temperature difference.

The message function can be deactivated by selecting “No”.

Message relay (error message)

Expert/Message rel.
 selection: „Yes“, „No“
 factory setting: „No“

Activate this function by selecting “Yes”. If the controller detects a fault, the message relay is energised (e.g. for signal lights).

These errors are:

- Sensor defective
- Real-time-clock (RTC) defective
- Storage module (EEPROM) defective

A message caused by one of the plausibility controls (non-

Message input

Expert/message inp
 selection: "Yes", "No"
 factory setting: "No"

In this menu, the message input Din is activated.

Chimney sweeper

Expert/chimney
 selection: "Yes", "No"
 factory setting: "No"
 Expert/chimney sweeper

This function is used for activating a given relay state when required.- e.g.flue gas measurement if the system controls a boiler. Activate this function by selecting "Yes".

Adjust the required relay status in the chimney sweeper menu (expert / chimney sweeper).

If the chimney sweeper function is activated, "chimney sweeper" is indicated in the main menu.

Solar shutdown

Expert/solar
 selection: "Yes", "No"
 factory setting: "Yes"

In this menu, the menu level and „solar“ control are deactivated. The sensors of the solar thermal system will no longer be monitored for errors.

Sensor offset

Expert/Sensors/CS-Type
 selection: A, B, C, D, E factory
 setting: E Expert/Sensors/CS
 adjust
 Expert/Sensors/CS Offset
 Expert/Sensors/Sensor 1
 (. . .10) selection: -5,0 ... 5,0 K
 factory setting: 0,0 K

Adjust the CS-type in this menu. The CS-type should be matched to the code letter printed on the CS type label.

The CS-offset adjustment should be carried out with the irradiation sensor disconnected.

Furthermore, an offset for sensors 1 ... 10 can be carried out.

Minimum speed

Expert/Relay/Min speed 1 (...3)
 adjustment range: 30 ... 100 %
 factory setting: 30 %

Relays 1 to 3 are semiconductor relays for pump speed control of standard pumps. Relative pump speed is adapted in 10 % steps to the current temperature difference between the collector and the store (see also 4.1 speed control).

In some cases, it is necessary to adapt the factory setting of the minimum pump speed (30%). If it is set to 100 %, pump speed control is deactivated (valves).

Language

Expert/Language
 factory setting: „Deutsch“

In the submenu „language“, different languages are available (German, English, French, Castellano, Italian).

4.5 Menu: Manual mode

manual operation/All Relays
 manual operation/Relay 1 (...7)
 selection: „Off“, „Auto“, „On“
 factory setting: „Auto“

In this menu, individual or all relays can be switched-on (relay test), switched-off, or set into automatic mode.

5. Troubleshooting

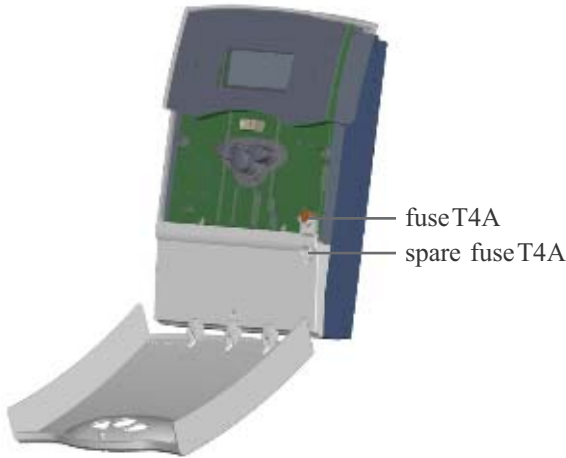

In the case of an error, a message is shown on the display of the controller:

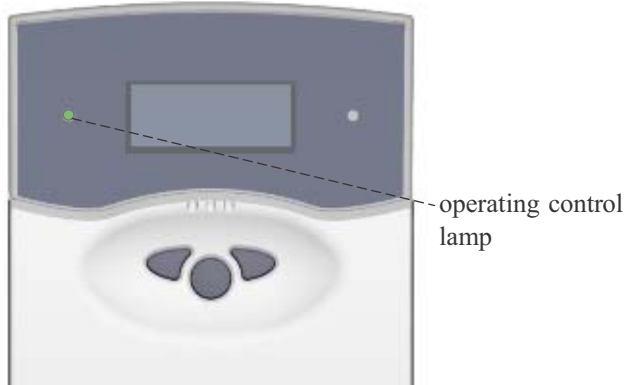

Control lamp flashes red

Sensor defect. An error code instead of a temperature is displayed in the sensor display channel.

888.8

- 888.8

Cable broken. Check cable.

Short circuit. Check cable.

Disconnected Pt1000 temperature sensors can be checked with an ohmmeter. In the following table, the resistance values with the corresponding temperatures are shown.

°C	Ω	°C	Ω
-10	961	55	1213
-5	980	60	1232
0	1000	65	1252
5	1019	70	1271
10	1039	75	1290
15	1058	80	1309
20	1078	85	1328
25	1097	90	1347
30	1117	95	1366
35	1136	100	1385
40	1155	105	1404
45	1175	110	1423
50	1194	115	1442

resistance of the Pt1000 sensors

Control lamp off.

If the light is off, check the power supply of the controller.

no

o.k.

The fuse of the controller is defective. This fuse can be replaced when the cover and the terminal cover are removed (spare fuse is enclosed in accessory bag).

Pump is overheated, but no heat transfer from the collector to the store, flow and return have the same temperature; perhaps also bubble in the lines.

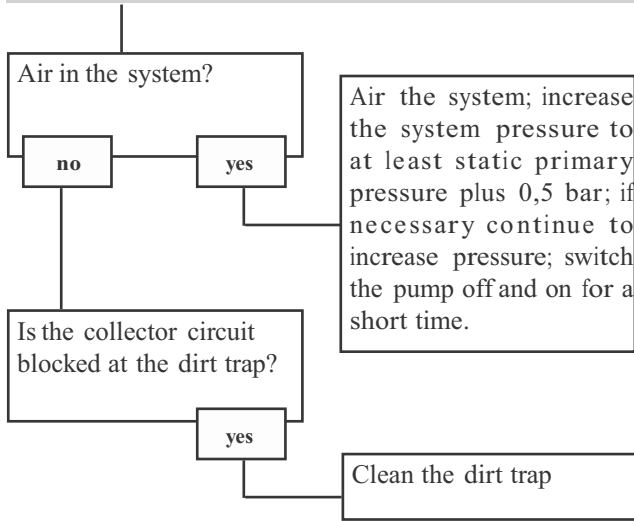

Pump starts for a short moment, switches-off, switches-on again, etc.

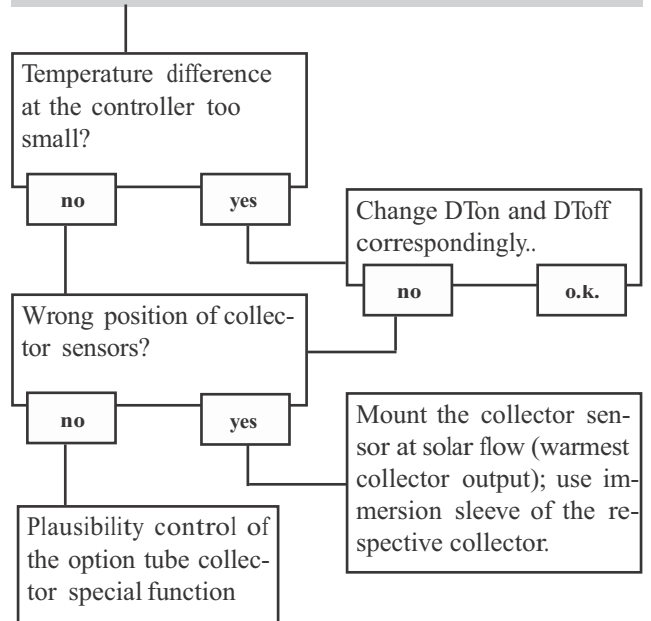

Pump starts up very late

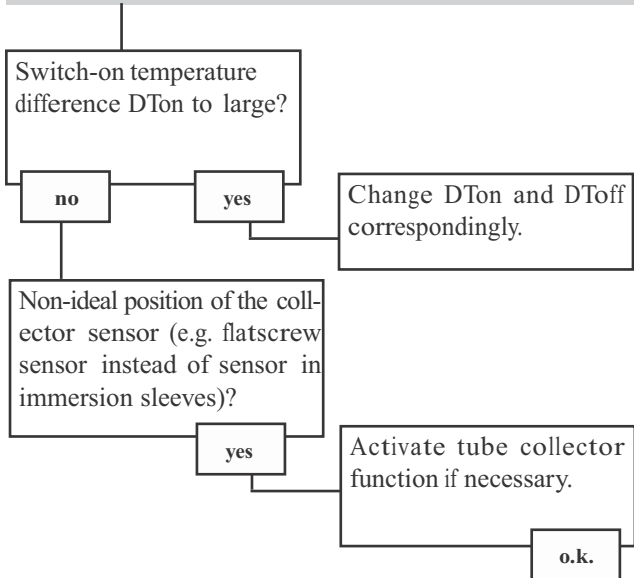

The temperature difference between store and collector increases enormously during operation; the collector circuit cannot dissipate the heat.

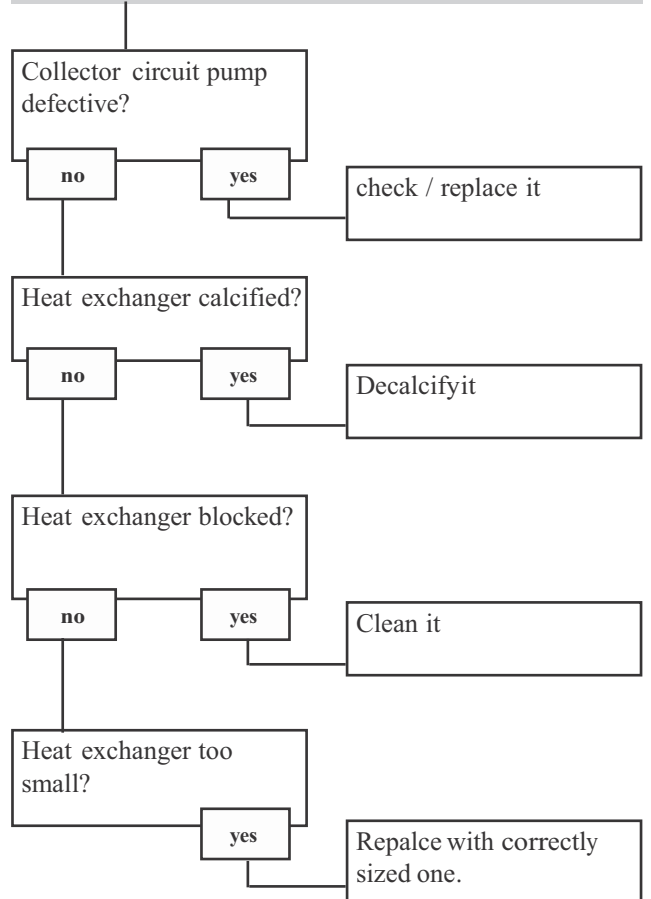

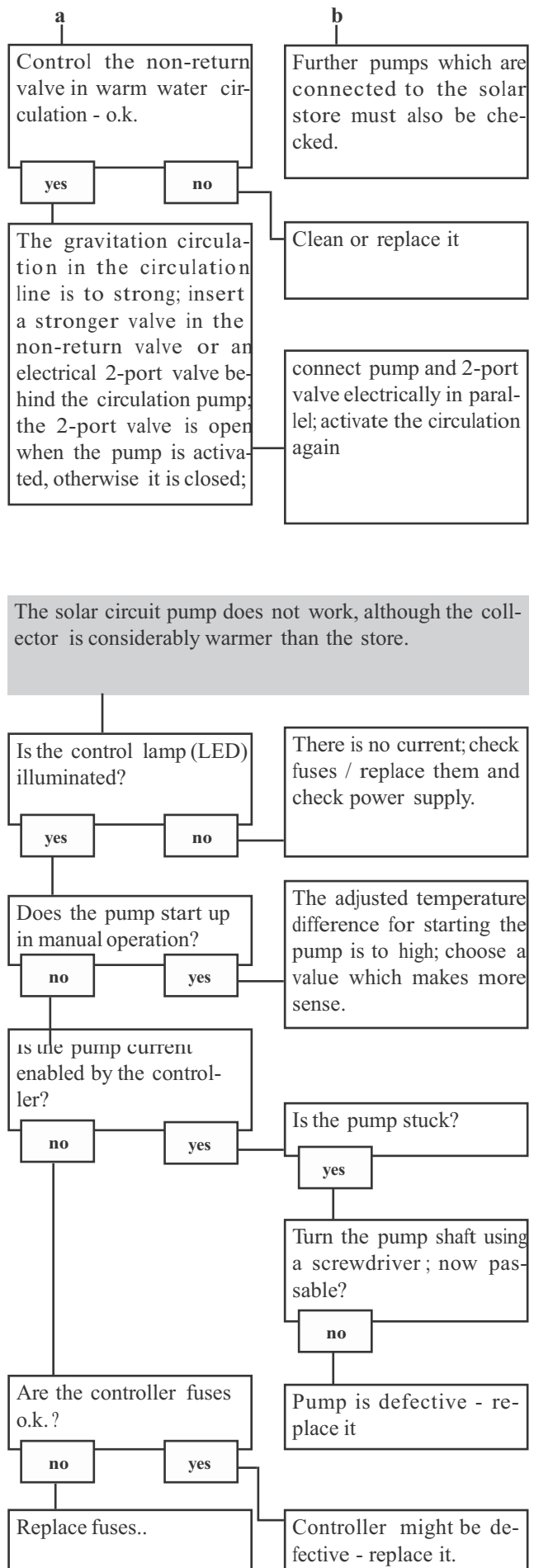
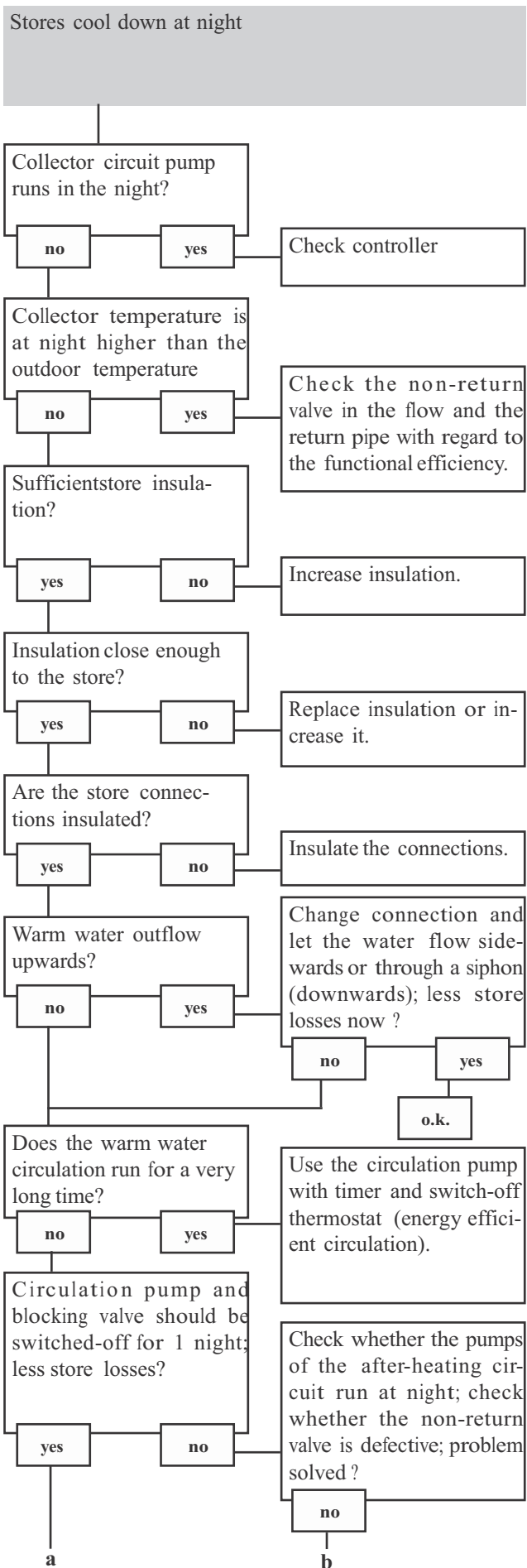

6. Accessory

Temperature sensors



sensor in immersion sleeves



clip-on sensor

Precision-platin sensors PT1000 (**FKP** and **FRP**) are used for the controller Solar Control 3020.

Depending on the individual solar system, the product range contains 3 different sensor types: sensors with immersion sleeves, flatscrew sensors and cylindrical clip-on sensors. The sensor types FK and FR have the same electrical features and are available in the same models, they only differ in the connecting cable:

FK: 1,5 m weather- and temperature resistant silicone cable for temperatures between -50 °C ... $+180\text{ °C}$, mostly used for collectors.

FR: 2,5 m PVC cable for temperatures between -5 °C ... $+80\text{ °C}$, mostly used for stores.

Overvoltage protection



Note:

In order to avoid overvoltage damage at collector sensors (e.g. caused by local lightning storms), we recommend installing the overvoltage protection **SP1**.

Flowmeter



The 40 is a measuring instrument with for detecting the flow of water or water/glycol mixtures and is used in combination with the calorimeter integrated into the Solar Control 3020. After a specific volume has passed the V40 reed switch sends an impulse to the calorimeter. The heat quantity used is calculated by the calorimeter using these impulses and the measured temperature difference with the help of pre-defined parameters (glycol type, concentration, heat capacity, etc.).

NAU GmbH Umwelt- und Energietechnik

Naustrasse 1

85368 Moosburg-Pfrombach

Tel.: +49 (0) 87 62/ 92- 0

Fax: +49 (0) 87 62/ 34 70

www.nau-gmbh.de

info@nau-gmbh.de



Subministraments i Muntatges Solars S.L.

C/Ausias March, 61

08205 Sabadell (Barcelona)

Tel. 93 712 02 82

sms@smssolar.es

www.smssolar.es

Please note:

The design and the specifications are to be changed without notice.

The illustrations may differ from the original product.